

**The 2003-2006MY Jaguar XK8 (Project X-103) Rev G dated 03/06/17 by Gary R. VanRemortel [vanremog@aol.com](mailto:vanremog@aol.com).** Welcome to an in-depth review of the Jaguar XK8. If you own one of these GT cars, I recommend you read this, get electrical diagrams, TSBs and research Jaguar Forum threads for addition details. Many XK8 related documents are available at [www.jagrepair.com](http://www.jagrepair.com). Exploded view parts diagrams are available from [www.sngbarratt.com](http://www.sngbarratt.com). Technical Service Bulletins often affect more vehicles than Jaguar acknowledges.

The [20032006MYXK8WorkshopManual.pdf](#) available as a 47MB CD from [www.jagdocs.com](http://www.jagdocs.com), covers the **VIN range A30645 to A48684**. Many routine maintenance items are simple DIY tasks, but others require specialized knowledge, proprietary tools and/or a lift. My particular 2005MY XK8 is a North American model (Left Hand Drive) convertible with 120K mi. Changes as the model matured have led to numerous errors in both Jaguar and aftermarket documentation. Part numbers included here for convenience should be confirmed against your VIN prior to ordering.



**Engine Type:** AJ34 4.2L (4196cc [256 CID]) DOHC aluminum alloy 32-valve 90° V8  
**Max Power/Torque:** 294 hp SAE @ 6000 rpm / 303 lb-ft SAE @ 4100 rpm  
**Bore/Stroke/Compression:** 86 mm / 90.3 mm / 11:1  
**Avg Fuel Economy:** 20 mpg  
**Fuel Capacity:** 20 gal  
**Spark Plugs/Gap/Socket Size/Torque:** NGK IFR5N-10 Iridium / .046" / 5/8" / 20 lb-ft  
**Oil Circulation Volume @ Max Pressure:** ~10 gpm @ 66 psig  
**Coolant/DI Water 50/50:** ~10 qt WSS M97B44-D (Dex-Cool OAT Orange)  
**Alternator:** ≥130A w/S6 Pulley  
**Battery:** DIN H8/LN5, Duralast H8-DLG  
**Acceleration (0 to 60 mph):** 6.3 sec  
**Max Speed (ECM limited):** 155 mph  
**Wheelbase/Width/Track/Length/Height:** 102" / 71" / 61" / 187" / 50"  
**Curb/Gross Weight:** 3993 lb / 4783 lb  
**Minimum Turning Radius:** 18 ft  
**Coefficient of Drag:** 0.36  
**Differential Fluid:** 2 qt 75W-90 Redline Synthetic  
**Power Steering and Soft Top Hydraulic Fluid:** Pentosin CHF11S  
**Brakes Front/Rear:** 325 X 28 mm slotted and drilled disc / 305 X 20 mm slotted and drilled disc  
**Brake Fluid:** Pentosin DOT4 LV  
**Wheels Front/Rear:** Keystone ALY59794U85 (19" X 8") / ALY59795U85 (19" X 9") Chrome Atlas  
**Lug Bolt Circle/Thread/Socket Size/Torque:** 4.75" [120.65 mm] dia / 1/2"-20 / 7/8" / 75 lb-ft  
**Tires Front/Rear:** P245/40ZR19 / P255/40ZR19



## Overview

The Jaguar XK8 is arguably one of the most esthetically pleasing and superb GT automobiles in the world. With regular attention it can be a great daily driver and, when well cared for, always draws attention. Used XK8s can be a bargain, so don't be afraid of them, if they have been well cared for.

Jaguar has chosen to discontinue supporting models older than 10 years and some parts used only on this model and not available as aftermarket are now starting to get scarce in the supply chain. Some of the finer details of the XK8 can lead to major owner frustration as they age, but many parts can still be bought at reasonable prices online. Since many repair shops have adopted policies against installing nonJaguar and/or ownersupplied parts, we are all likely to be in a DIY situation at some point. Access for repair can be difficult because systems are tucked into every nook and cranny of the car, and this is part of the reason Jag technicians make good money. I encourage you to do routine repairs and maintenance yourself if you can. Taking digital photos during disassembly is good practice. Many USB endoscopic cameras are now available for \$15 on Amazon and they are really good at inspecting and capturing detail within tight areas. Any good mechanic also needs a headband lamp and the Nathan Nebula Fire is great USB rechargeable one.

There is a high degree of consistency across the automotive industry, but Mainland Chinese made parts can be of lesser quality. OEMs learn from one another's designs and adopt what does the job at the lowest price point. Be very careful when starting threaded fasteners into aluminum and do not over-torque fasteners, as you can easily strip rather finely pitched metric threads. Thread engagement into aluminum should be >3 times the fastener diameter (twice that of fasteners into steel). Plastic items can break easily as they embrittle with engine bay heat over time. When disconnecting PA12 GF20 Normaquick V2 RSS pipe connectors, it helps immensely if the engine bay is still warm or you can crack their retention features. As long as you don't break the connectors, cracked pipes can be refreshed/refurbished. **Always remove Orings/seals using a soft smooth nonmarring tool. Lube them prior to installation (I use Krytox RFE).**

I use the RC hobby equivalent of a turkey baster (Sullivan Products Glow Fuel Bulb), with a 6" length of RC fuel line to suck out old fluid from brake and power steering reservoirs and refill yearly. Always chock the opposing wheel set and use well placed jack stands for safety along with your trolley jack. I have a pair of \$45 six ton rated Blitz Rhino plastic ramps that raise the car 6". Ensure your tool kit (in the trunk beneath the spare tire) contains a Towing Eye HJA4333AC (M20X2.5 right hand threaded), as they often get forgotten at initial dealer prep. The terms left/right used herein are relative to the driver's seated position.

## Body

High-strength steel members throughout the car assure a rigid body structure, while crumple zones at front and rear corners are designed to absorb forces in a crash. Triangulation braces run from the firewall to strut towers and convertibles have additional cross-bracing under the engine bay, stiffening members in door sills and a reinforced windshield frame, helping to reduce scuttle shake. These braces may need to be removed to access some areas for repair. The body mounts to a modified XJS floor-pan. The bodyinwhite is both stiffer and lighter than the XJS. Torsional stiffness is improved by 25% and the body structure consists of 30% fewer panels. Modern highstrength steels are used in panels subject to highest loads (approximately 15% of the body), including front longitudinal members, seatbelt anchors, suspension mounting points, bumper mounts and side impact beams within each door. Watch the panel joint under the door sills especially on the convertibles to ensure that you are not getting paint cracking in this area indicating possible structural damage.

A quiet, draft-free interior is the result of several factors: a worldclass sealing system, a fully lined and padded soft top, 5 mm thick heated rear glass and attention to detail by design house Karmann of Germany, who shared in body development work.

## Engine

The Jaguar designed and manufactured closed deck (no valley pan) AJV8 engine has 5 plain bearings and is compact, lightweight (441 lb) and strong running all the way to its 6400 rpm redline. Thrust washers are provided either side of the center position and the crankshaft is spheroidal graphite cast iron. Unlike the V12, the torque curve rolls off noticeably below 2000 rpm, but this tradeoff returns good mileage in fifth and sixth gears at US freeway speeds. The line drawing below shows the structural sump mating to the bedplate which mates to the cylinder block, providing exceptional rigidity, durability and refinement. Krebsoge sinterforged steel connecting rods are fracturesplit at the crank end.

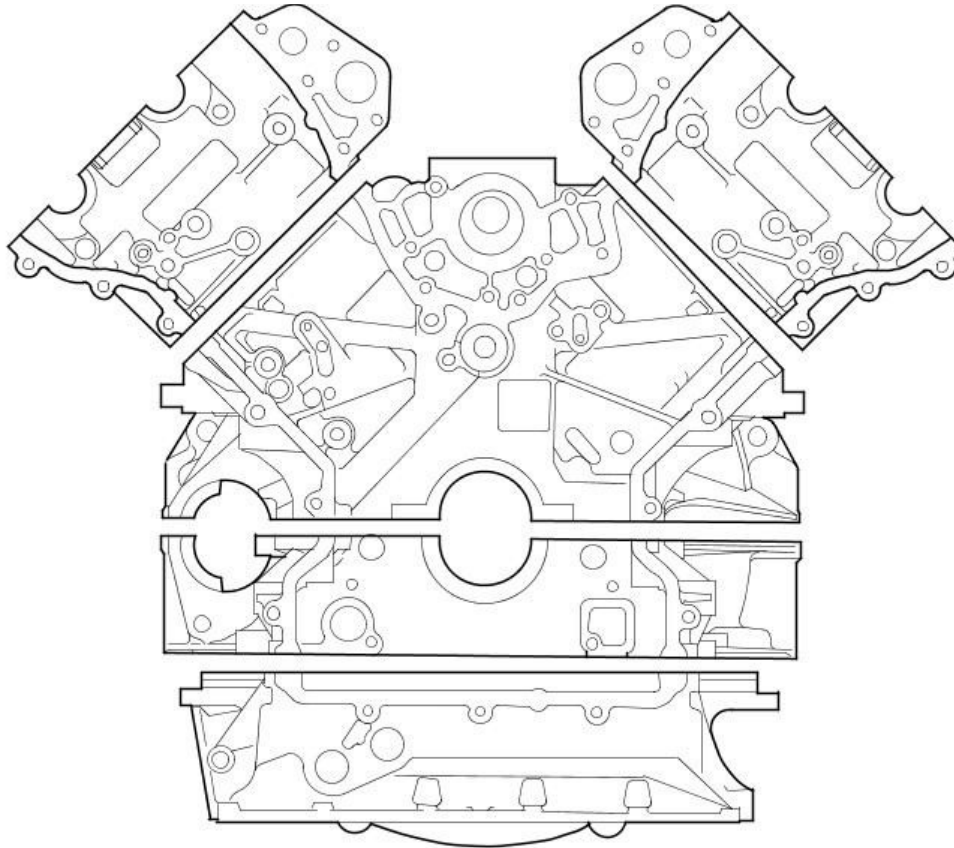

The original Jaguar AJ26 4.0L engine established itself as a class leader in weight, stiffness, low friction, high power output and efficiency. The engine was updated to improve performance, emissions and economy to the point that the very few things that go wrong are relatively easy DIY fixes. 4.0L engines suffered from eroding Nikasil cylinder plating (due to high sulfur in fuel at the time, combined with excess moisture brought on by short trips). 4.2L engines all have iron bores and an output graph for the naturally aspirated engine is shown below. BSFC is a very efficient 0.40 lb/hp/hr and warm cylinder compression is around 190210 psig for the naturally aspirated engine. The cold starting idle is around 1100 rpm, dropping to 650 within 45 sec. Ref TSB 303-12.



## Valve Train

The 4.2L engines introduced in the XK8 2003MY use Morse Hy-Vo (inverted tooth) primary chains and aluminum bodied chain tensioners, rather than simplex primary chains and plastic bodied tensioners of the original 4.0L. These more robust components better handle the abrupt intake cam torsional load reversals that occur in naturally aspirated Variable Valve Timing (VVT) equipped engines, as the cams rotate up to 48° in 0.7 sec. Gundrilled camshafts, shimmed-for-life inverted bucket lifters and light (5 mm dia) valve stems keep valve train mass and cam loads low. Intake and exhaust valve axes are 28° apart in the Cosworth designed pentroof heads, forming ideal combustion chamber geometry. Jaguar specifies Premium (91 RON) unleaded fuel. Valve lift is 9 mm and clearances are .008" intake, .010" exhaust.



## Ignition

Ignition is via a world-class NipponDenso 32-Bit electronic management system. Individual pencil coils AJ810445 (differing from those on the 4.0L) are each retained by a single bolt. From 2003 on, the cylinder designations now meet ISO standards, Bank 1 (right side) being 1, 3, 5 and 7 and Bank 2 (left side) being 2, 4, 6 and 8 front to back. Firing order is 12734568. Spark plugs in this high energy system should be replaced every 75K mi with robust single electrode types. Ref TSB 303-29. A good magnetic socket is required to extract plugs from their rather deep wells. Any oil found within plug wells is either leaking from valve cover seals or the plugs were not properly torqued. Plugs are easily accessible and changing them is an easy DIY job, taking about 30 minutes.

Clearing existing ECM Adaptations can expedite the adaptive learning process for some functions. Ref TSB 303-01.

## Lubrication

These engines require 8 qt of 5W-30, 10W-30 or 5W-40 synthetic oil. I order Pennzoil Ultra Platinum 10W30 with PurePlus™ Technology available in a 5 qt jug for \$28 from Amazon or Walmart. I recommend a Mahle OC602 or Mann W719/7 oil filter (both \$15 from RockAuto). Be aware that cast-iron sleeves allow more oil loss than do Nikasil lined bores. A FilterMag SS300 placed on the oil filter pulls any ferrous swarf out of the oil. A Fumoto F106SX (M14-1.5 thread) oil drain valve makes oil changes easier. Never let the oil level get low — if the LOW OIL light ever comes ON, STOP and top off immediately. If you have oil leaks, Tracer Products makes a kit consisting of dye and black light.

The 4.2L cars have an oil cooler sitting in front of the radiator just below the power steering fluid heat exchanger. The oil hoses running from the front of the engine to the intermediate pipes should be inspected regularly. Ref TSB 303S846. I recommend a 10 yr replacement, regardless of mileage, because the consequences of failure are so dire.



## Cooling

A low volume, split flow, high exchange rate cooling system allows the engine to reach operating temperature (190°F coolant temp) in <4 minutes, contributing to ready drivability, low emissions and good fuel economy. The engine block temperature is said to vary less than a few degrees from one corner to the other. Better insulation than the light aluminum heat reflectors should have been used to protect the cabin from the heat of the engine, catalysts and center muffler. Waste engine heat makes the cabin cozy in winter, but in ambient temperatures above 75°F the A/C is needed if you have the windows and top up.

Coolant is Extended Service Life Organic Acid Technology (OAT) ethylene glycol (Dex-Cool colored orange, meeting WSS M97B44-D). Ref TSB 100-16. Sebacate and 2-EHA make up about 5% of DexCool and may attack plastic/rubber parts in the cooling system, leading to gasket leaks. The additives are depleted in the process of protecting aluminum surfaces, requiring a coolant change every 5 yrs and anytime you replace the radiator or pump. I pressure test the system using a \$70 Harbor Freight #69258 pressure tester. The GREEN #21 adapter fits the expansion tank neck perfectly, without having to pinch off the atmospheric recovery tank hose. This kit doesn't provide a way to test the cap, but caps are cheap to replace. Back flushing and flow testing should be done or the radiator replaced somewhere around 150K mi. The plastic expansion tank MJD4400AB is a robust part, but its rather frail magnetic float sender is pretty much toast by 75K mi. The tank includes cap and sender for around \$140.

Visually check for coolant seepage at the weep hole on the underside of the coolant pump housing halfway between the rear and front bearings. Check for gasket failure, evident by a dirty orange buildup on the engine block around the pump (because boiled out glycol becomes sticky). The original 4.0L pumps had black nylon 6/6 impellers which degraded in short order, leading to some overheated engines early on. Ref TSB 303-60. Impellers were changed first to black PolyPhenylene Sulfide (PPS) and then to white PPS. All 4.2L engines got the latest pumps, but plastic impellers have been known to spin on their shafts. Aluminum impeller equipped equivalent pumps AJ88912/X are readily available. These pumps are well made, last for ~100K mi, should be supplied with a metal composite AJ83300 gasket and changing it is an easy one hour DIY job. A vestigial Oring between the gasket and engine block shown in some literature is no longer required, but doesn't hurt. Change the serpentine belt, thermostat, pump and check the idler/tensioner pulley bearings at the same time. For some reason Jaguar recommends replacing the three pump pulley bolts AJ81256 (Find No. 5 in the line drawing below) even though they are not stressed much in this installation (the center boss carries the entire side load). Then they add insult to injury by pricing them outrageously. I reused the original bolts.

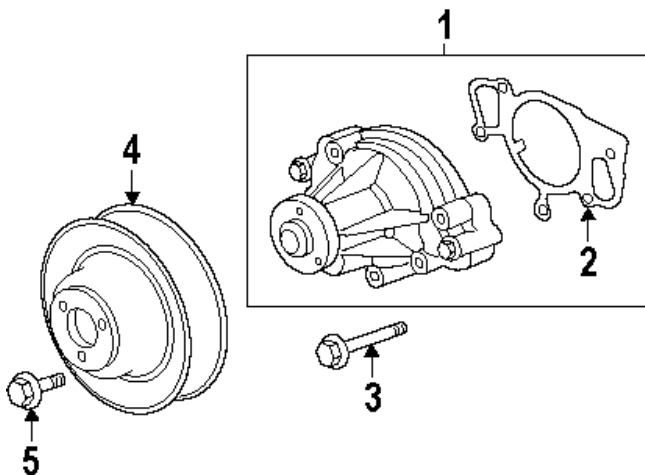

The Coolant Outlet Pipe Assembly AJ89486 (\$100) on the 4.2L engines differ from the 4.0L and consist of three separate plastic moldings (Thermostat Cover, Pipe and Rear Duct), a four-piece thermostat, a temperature sender and five sealing rings (AJ83525, two C2C11477010, AJ83526 and AJ82697). The entire assembly should be replaced every 60K mi, since the pipe is known to stress crack at the top and consequences of this failure could be dire. There is no aftermarket aluminum version of the outlet pipe assembly for the late model XK8s. Removing the intake manifold end plate is the only way to gain access to the rear duct aft two bolts. Upon reassembly, lightly seat all 8 pipe and duct mounting bolts to get everything properly lined up. Draw the square plastic bosses on top of the duct and pipe together with a spring clamp while you finish torquing the bolts. Outlet Pipe Assembly replacement takes about an hour. Be sure to pressure test the system at 1 bar to check for leaks.



The coolant hoses to the radiator are C2N1173 (lower) and C2N1174 (upper). The OEM “constant tension” spring steel hose clamps should always be replaced along with the hose.

A 14.5 psi rated expansion tank cap MJA4440BA at the very top of the system combined with an atmospheric recovery tank located low in the right front wheel arch is proper for Dex-Cool systems, as expelled coolant returns during cool down. Keep the atmospheric recovery tank at least ¼ full of coolant or the plastic tubing “straw” can un-port (suck wind). The pressurized portion of the system should never exhibit an air pocket, as air combined with high heat is reported to cause gelling of Dex-Cool. If air is getting in, either there is no coolant in the atmospheric recovery tank, the “straw” has a leak, the pressure cap is bad or there is a plumbing leak elsewhere in the system that must be found and fixed.

Cut a 2” dia hole in the rear of the right front wheel arch liner about 9” up from the sill and install a removable black plastic sheet metal plug. To check the tank level, remove the side repeater lamp and shine a penlight in. An occasional slight glycol smell while running or upon shutdown with this system does not necessarily mean you have a coolant leak, since the atmospheric recovery tank is vented beneath the chassis. If the low coolant light ever comes ON, STOP immediately, top off and ensure the recovery tank is at least ¼ full.

A plastic burp line runs from the thermostat tower assembly to the expansion tank. Since it is captured between the plastic engine cover and intake manifold, it sees substantial heat. I replaced mine with 5/16” [8 mm] ID reinforced silicone hose from Z1 Motorsports. As long as you’re at it, replace the short hose segment connecting the plastic tubing going to the atmospheric recovery tank to the rear nipple of the expansion tank with a piece of the same hose, as the OEM hose is prone to swelling and leaking here. Between the engine block and the intake manifold run valley hoses supplying coolant out to the heater matrix via the octopus hose. The feed hose AJ86326 runs on the right side and the return hose NNE3946CA on the left. Some owners have replaced these with straight runs of silicone hose. With careful maneuvering, the feed hose is replaceable without removing the intake manifold, but not the return hose. The composite intake manifold gaskets on the 4.2L engines are two contiguous strips rather than 8 individuals.



The main radiator is divided into a coolant portion and a transmission fluid portion. A thin A/C radiator core sits in front of the main radiator. At the lower front is yet a fourth cylindrical heatexchanger to cool power steering fluid. The drain-plug JLM20622 (Dorman 61138 is identical at half the Jag price) is located at the bottom of the right radiator end cap facing aft and is a bit fiddly, having a hard pipe partially in the way, preventing a straight shot at tightening it with your screwdriver. It has a rubber seal under the head and barbs on the end to retain it in the port when unscrewed. It is molded black polyethylene with M10-1.5 threads. Be careful not to over-tighten it or you may develop slow seepage that might not show up on the ground.

Two rather fiddly square head bolts retain the top of the fan assembly against the radiator. It would be wise to wedge some foam or double-stick tape in between their heads and the molded radiator slots to keep them in place when removing and reinstalling the fan assembly.

### Serpentine Belt

The naturally aspirated 4.2L engine uses a single .82" width X 91" length 6 rib serpentine belt AJ89191, Dayco 6PK2310 (5060910) or equivalent, generally lasting around 75K mi (or 6 yrs). The belt spring tensioner is released using a 3/8" square drive bar. Ref TSB 303-02. Replacement is an easy DIY job taking about 30 minutes. Tensioner and idler pulley bearings are good for 150-200K mi. Keep track of your gas mileage as the car ages. The increased friction of tensioner and idler pulley bearings going bad shows up as progressively poorer mileage. They're cheap to replace.

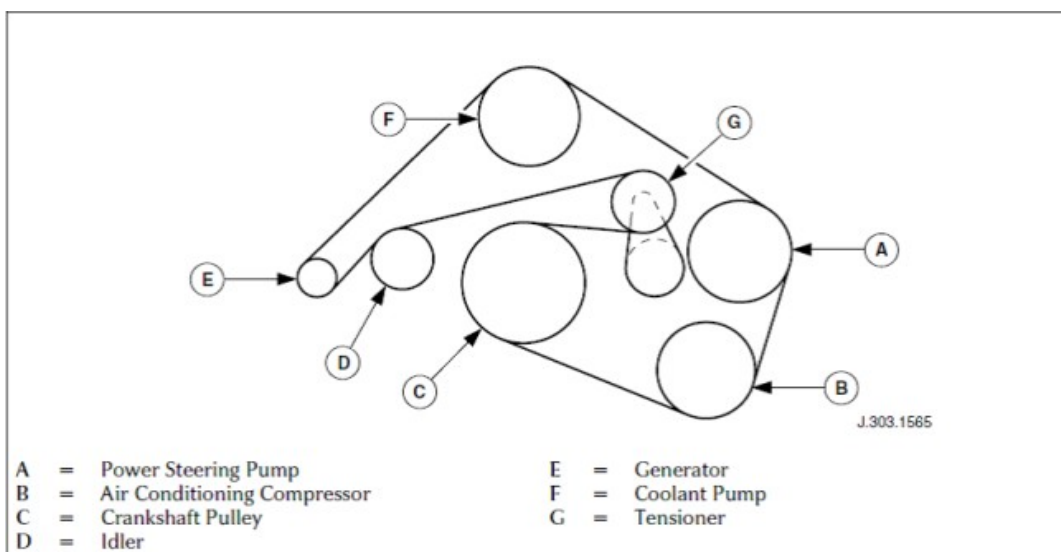

## Induction and Crankcase Ventilation Systems

The induction system begins with a vent in the right front fender feeding directly into the lower portion of the air box, through the filter, through the air box cover and integrated MAF sensor, into the induction tube C2N1041 to the rear mounted throttle body. It is fairly restrictive because of the bellows and turns and some have converted the fog lamp openings into ram air ports. The bonnet liner/insulator blanket sags in its fastenings over time and it can brush lightly against the crests of the bellows section of the induction tube if it's not well seated.

Reusable filters like the K&N 33-2190 are available for the stock air box and the Mina Gallery Cold Air Intake kit may be an improvement over the OEM air box design. The clamp pivot bosses on the OEM box XR823351 crack from clamp stress and engine heat at around 75K. It is fortunate that the bottom portion of the N/A air box has been unaltered since day one and used ones are still available for <\$50. The M6-1 threaded rubber shock mount EAC8130 \$70 often tears/separates over the years. Some have replaced them with similar, but more reasonably priced items (EAC6805, EAC6806 and MNA6730AB or similar cotton reel rubber mounts may fit). If your air filter is working properly, you will only need to clean your MAF sensor C2S2670 every 100K mi using a commercial aerosol MAF sensor cleaner. The sensor can be unplugged and removed from the duct collar for easy cleaning.

All air going into modern engines must be metered, so make sure that all plumbing and O-rings are tight and can hold vacuum. Cam covers have internal mesh filters and a crankcase ventilation control valve AJ87773 sits on Bank 1 and the oil filler neck on Bank 2. For the 4.2L, there are no longer restriction orifices in either of the cam cover ports and the full and part load breather pipe functions are reversed from that of the 4.0L. A Norma V2 NW15 mm part load breather pipe AJ88622 on Bank 1 connects the control valve to the intake manifold, providing vacuum at partial throttle. A Norma V2 NW10 mm full load breather pipe AJ87221 on Bank 2 connects to the induction tube to provide vacuum at full throttle. The control valve regulates flow as the differential between the two vacuum sources changes. OEM pipes are corrugated for easy forming, but their thin walls become brittle over time while getting baked in engine heat. Jaguar nor the aftermarket supplies these parts any longer. I think I bought the last AJ88622 in the free world from Norway. If you need either of these pipes, I can make OEM equivalent or custom versions using smooth bore PA12 tubing (much more robust than corrugated pipe). If your connector ends are intact, it's cheaper to you, as they can be reused on the new pipe.

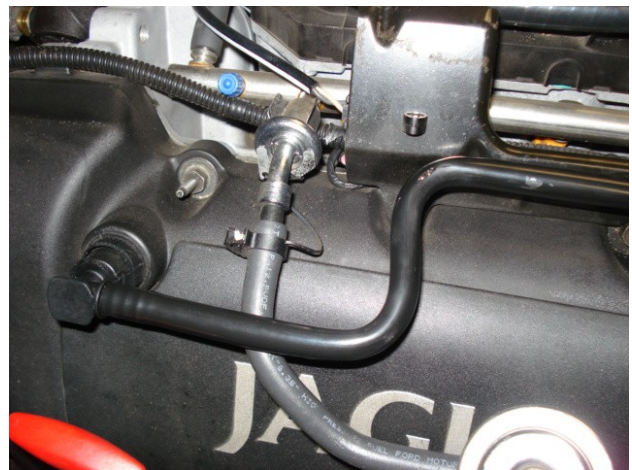
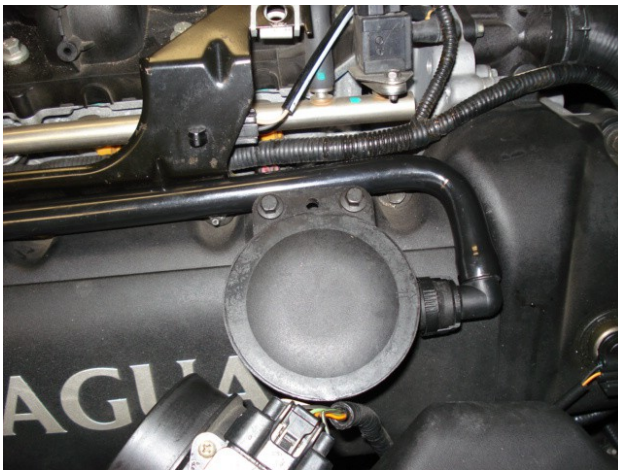

Crankcase ventilation unwittingly pulls suspended oil droplets into the intake, fouling everything downstream and degrading the combustion process. Googling 'Air Oil Separator' yields a dizzying array of bizarre plastic and/or metal gizmos all designed to remove submicron oil particles from crankcase gases. OEM systems generally try to return captured oil to the crankcase, while aftermarket systems give you the option.



Corvette owners are keen on the Mann Hummel Provent 200, but it is physically much too large for our limited space. The Provent 100 (P/N 3931070792) \$80 from [www.diesel-filters.com](http://www.diesel-filters.com) (as shown in the photo above) is easily modified to support the blow-by volume of the AJV8 by replacing the coalescing filter element with a round metal screen in the bottom (to create an oil collection sump), a stainless steel pot scrubber pad (low restriction permanent media on which the oil can collect) and defeating the top vacuum shutoff valve (by cutting the center diaphragm out). Seal the upper cap and cover on permanently with Fusion Urethane Adhesive or High Temperature RTV or the unit can develop leaks over time due to its light construction and poor gasket sealing area. For safety's sake, make absolutely sure the unit will not develop leaks, as loss of engine vacuum can affect the braking system as well. Once modified in this manner, the flow direction no longer matters, allowing greater flexibility in plumbing. The Bank 1 crankcase breather pipe is the same on both ends and is easily hacked to insert the unit inline by cutting in the center of the cuff join (smooth section), reversing it, warming the corrugated sections to ~300°F and reforming as necessary. I ended up junking the embrittled OEM corrugated pipe, made a new custom smooth PA12 pipe and cut up some valley hoses to get appropriately joggled 3/4" ID joiners. The hookup is pretty straightforward if an oil return line is not plumbed, but you will need to drain it at every oil change. I JB Welded a 1/4" barbed right angle fitting into the drain port of the Provent 200 and ran reinforced silicone hose out to a remote drain valve. I trap >1 oz every 5K mi.

I like having an accessible mechanical vacuum gauge port, so I cut the hard plastic line leading from the throttle body to the brake booster (it makes a wide U-turn back to the right and then goes left back near the firewall) and grafted in a capped 1/4" barbed brass tee. **Just make absolutely sure there are no leaks or your power assisted braking can be impaired.** High temperature black silicone nipple caps are available in a wide range of sizes from [www.034motorsport.com](http://www.034motorsport.com). There is a kit C2S15816 for replacing the vacuum line end fitting in the throttle body if you develop leaks here.

## Fuel System

Beginning with the 2003MY, a returnless fuel system was adopted from Ford. A new plastic jacketed vane pump C2N1146 with integral float sender and particulate filter sock sits in the tank. All submerged fuel pumps rely on fuel in the tank for effective cooling so you should always fill up at 1/4 tank. Do not overfill the tank or you may foul the vapor canister system. Advantages of returnless systems are lower vapor loss, fuel line routing is simpler with fewer opportunities for leaks and the reduction in circulated volume allows for a smaller inline filter. The Fuel Pump Module (FPM) tries to maintain 55 psi, relative to manifold absolute pressure. MAP (in this case negative pressure) at idle is 20 inHg [~10 psi of vacuum] and is subtracted from fuel pressure reported by the OBD2 system to equal that measured by a gauge at the fuel rail Schrader valve (~45 psig). The vapor recovery canisters are now mounted behind the rear axle and as the exposed hoses degrade over time, you can expect leaks here.

The hottest temperatures under the bonnet of an all alloy engine occur right after engine shutdown and can stay quite high for almost an hour. Anytime an engine is shut down and started back up before it has had sufficient time to cool, vapor can form in the fuel rail. Winter blend fuels increase this tendency. Much of the heat formerly carried into the fuel tank by a return type system now contributes in vaporizing the light ends of fuel trapped in the rail. I wish Jaguar would have done a better job of isolating the fuel rail from conducted engine block heat. If you get a lazy fuel injector, the engine may start, but idle poorly. A scan tool may show DTCs P0301 through P0308 and, if it happens again over a short period of time, you might get a Check Engine Light (Malfunction Indicator Light or MIL) and DTC P0316. It also means it's probably time for injector cleaning and flow balancing.

There is no longer a fuel pump relay. The FPM gets its commands from the Engine Control Module (ECM). When the ignition key is ON, 12VDC is supplied via F5 in the boot fuse box through the FPM to the pump. During engine operation, the ECM polls pressure and temperature sensors in the engine compartment and commands the FPM to duty cycle the ground circuit of the fuel pump (between 5 and 50%) to maintain appropriate fuel rail pressure. When things go wrong, it can be difficult to determine which component in the system is at fault without specialized diagnostic equipment.

### Returnless EFI

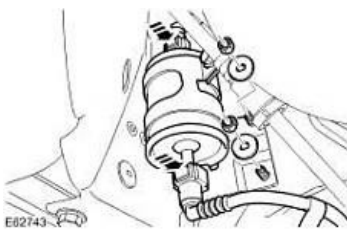
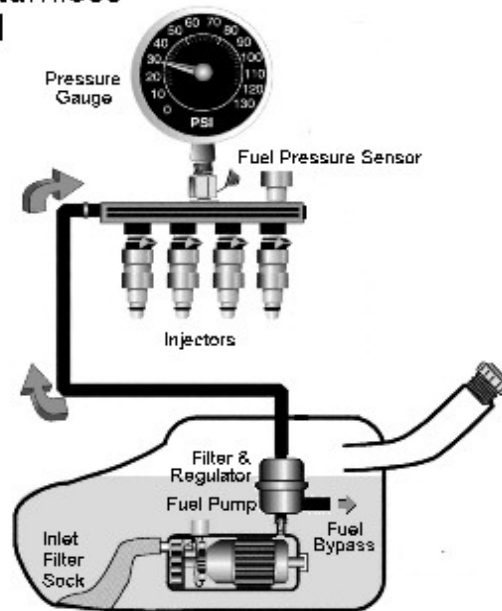

E02743



The inline fuel filter, located near the left rear wheel arch just ahead of the axle, should be replaced every 50K mi. This OEM filter C2S20977 has changed for 2003-2005MY, although many parts suppliers haven't yet gotten the word. Instead of threaded hex nut Oring sealed ports of pre2003MY filters, the new style filters have 5/16" [8 mm] dia straight tubes with raised circumferential ridges halfway down to capture radial clips in NormaQuick fittings. My filter had P/N 1X439155AA "Made in Poland" stamped on it and that P/N crossreferences to Mahle KL83 and Mann WK512/1, (both \$20 from Amazon). You'll need a plastic release tool like Lisle 39410 and you need to drive it firmly and deeply into the fittings to release.

**Before you begin, pull F5 in the boot fuse box and try to start the car to reduce fuel line pressure.** It helps immensely if you get the back end of the car up on jack stands and remove the left rear wheel. Two 4" long 1/4" square drive extensions snapped together are needed to reach the 10 mm headed nut holding the filter bracket to underbody before releasing the NormaQuick fittings. Fuel will not siphon out of the tank with the filter disconnected, provided the pump is not powered up. Some fuel in the line will blast out, but the volume is small. The flow direction is shown on the filter and the rimmed end of the filter faces down (forward). Any supplementary plastic barbed fittings supplied with the new fuel filter may be discarded. It's about a 45 minute job, with reassembly being the reverse of disassembly. Make sure the quick disconnect fittings are snapped back together properly before you reinstall F5 and pressurize the system to check for leaks.

Near the fuel rail fitting is an inline Pulse Damper. It's not a regulator, usually causes no problems and its job is merely to smooth out pressure variations (pulses) in the delivery system. Disconnect the fuel line at the rail by un-hooking the safety clip and use a 1/2" fuel line tool (310D005 or equivalent) to release the quickdisconnect fitting. There are two Orings and you need to pull hard until the fitting releases. The fuel rail itself is pretty straightforward and consists of two interconnected pipes, the right pipe having a front mounting flange for the fuel pressure sensor and a rear mounted fuel temperature sensor. There is a common Schrader valve on the left side pipe next to the fuel supply line fitting. Disconnect vacuum line and sensor connectors and remove the entire rail with injectors still attached. On the bench remove each clip and injector from the fuel rail one at a time. Mark them with cylinder numbers for reference.



2003-2006MY US market XK8s use Denso (not Bosch) fuel injectors (orange). These particular injectors (also used by Land Rover, Ford and Mazda) have improved targeting and 12 teeny tiny orifices you must keep fastidiously clean. These 20 lb/hr @ 3 bar injectors use EV6 (Black w/red insert) type connectors and are high impedance (13.6 Ohm) type. If you ever need a replacement, they are Jaguar AJ82363, Ford 2W93-AA or Denso 1955004280.

Fuel injector cleaning solvents in the fuel tank help, but this alone won't keep these particular injectors free from muck build-up over the long haul. Injector orifices and pintles accumulate varnish over time and valve action can become sluggish. Inlet filters can supposedly be removed by chucking a sheet metal screw in a vise, screwing the injector over it and gently rocking it back and forth to extract, but this didn't work for me. My filters were clean after back flushing, so I just left them in. If you need new inlet filters, [www.MrInjectorUK.com](http://www.MrInjectorUK.com) has them. There are a number of DIY oncar solvent flushing systems (OTC 7448 and others) available for between \$120 and \$220, or you can build your own for less than half that. Offcar cleaning is much more effective than forward flushing of the fuel rail and injectors in situ, since you can then clean/replace screens, back-flush, verify spray pattern and confirm flow matching on an individual basis. Flush the rail with Berryman's B-12 while you have it off.

If you suspect you are having individual injector firing issues, a Noid light (Lisle 27800) or current limited LED can confirm that turn on pulses are being received at each cylinder from the ECM. If you confirm good pulses, then the problem is likely with the injector(s). Another method is to hold a long bladed screwdriver up against the operating injector body and the handle to your ear as though it were a stethoscope.

When cleaning injectors, keep volatile solvents contained, ground all static sources, keep sparks away, use a safe/low TURN ON voltage and keep duty cycle lower than 80% to avoid overheating the coils. Keep in mind when an injector shuts OFF, back EMF from the collapsing flux field produces a sharp spike. Use a reverse biased (cathode to +V) catch diode such as 1N4005 in parallel with the injector in any switched circuit as a discharge path. New pintle caps 2-252 are available from InjectorRehab and should be seated on injectors and the filters reinstalled using an arbor press. Replace the 8 mm x 3.5 mm Viton top and 9 mm x 3 mm Viton bottom Orings. Reseat each injector individually into the rail and reinstall the retention clips before reattaching fuel rail and final leak testing.

There are also many good injector cleaning services out there using ASNU or similar bench flow matching systems. WitchHunter, LinderTech, AUS Injector and Injector-Rehab all do good work.

## **Throttle Pedal and Throttle Body**

The throttle body for the 4.2L is all new, simplified and pretty trouble-free. The ECM automatically adjusts for butterfly position and it just needs cleaning using B-12. The electronic drivebywire throttle gives smooth accurate power delivery, although an overly robust pedal return spring continually fights you. There is a kickdown button near the limit of accelerator pedal travel akin to engaging warp drive. There is a special tool and procedure in the XK8 Workshop Manual for adjusting the cable tension from pedal up to sender. Upgraded custom pedal covers are available online from Ultimate Pedals.

## **Transmission**

The ZF 6HP26 6-speed automatic gear box is quite robust and has found its way into many brands of luxury sedans and sporting cars. The single planetary and dual planetary (Lepelletier) gear set provides six forward gears (ratios are 4.17, 2.34, 1.52, 1.14, .87 and .69) supporting engines up to 444 lb-ft of torque. This box incorporates Bosch Mechatronics and there is substantial shift lag. When placed in reverse (ratio 3.40), the ECM limits maximum throttle body opening to 18°. ZF specifies their Lifeguard6 fluid, but Redline D6 is an acceptable alternate. The fluid and filter/pan should be changed out every 50K.

Like many modern transmissions, there is no dipstick, Jimmy. Always confirm you can loosen fill plug before you remove drain plug. Only about 6-7 qts of the total 10 qt fluid capacity are accessible during filter/pan drainage (the balance being trapped in the torque converter, lines and cooler). Refilling this way involves pumping fluid, while running the engine, shifting through all gears, measuring fluid temperature, pumping more fluid, until fluid drips out, and then installing the fill plug, all the while working around hot exhaust pipes. Some claim a better result is achieved by flushing the transmission via cooler lines. You will need to decide for yourself which method you prefer, as each has its advantages.

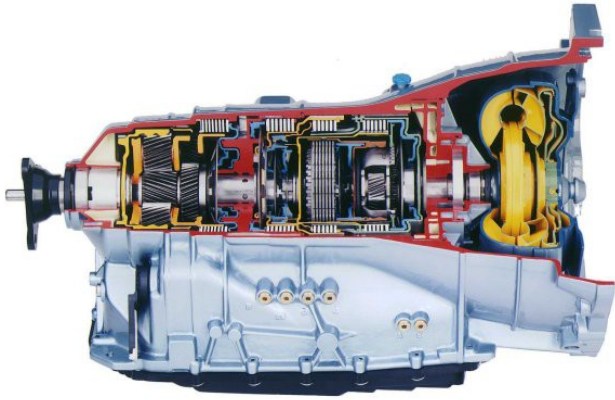

The Type A plastic filter/pan C2C38963 or ATP103178 is widely available. The 21 filter pan fasteners on early versions of this box had T27 Torx driving recesses and apparently enough of them were getting stripped out during filter changes that ZF switched to screws with T40 driving recesses. Check yours in advance and if you have the older screws, I recommend getting the new ones CTSC 0736 101 486 01 and install them with a little anti-seize compound. The connector sleeve CTSC 0501 216 272 01 should also be changed as long as the filter/pan is off. Examine the magnets and filter/pan for swarf.

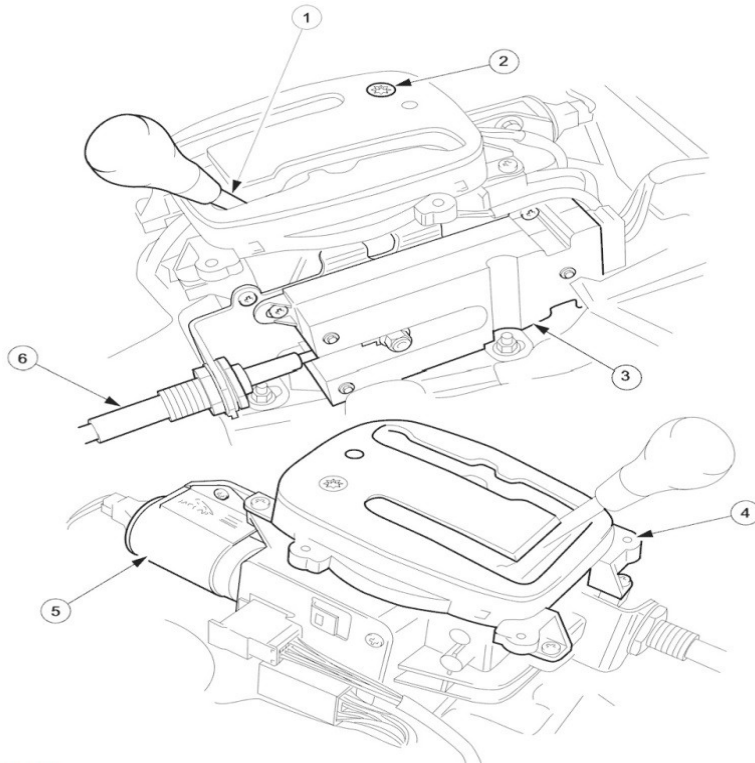

Refer to the line drawing above. On the shifter surround there is a T40 Torx headed screw/plug (Find No. 2) that must be removed and the shifter lockout defeated if you ever have to limp home with a failed brake pedal position switch. After a time, the gearshift interlock solenoid (Find No. 5) can make a clacking sound when you put your foot on the brake pedal with the shifter in PARK and I ended up putting some peel and stick EPDM foam on the inside of the lower forward plastic housing where the release pawl moves, to soften its stop. I also never liked the clunking sounds the stick made in the console during manual shifting, so I packed the shifter surround internally with 1/2" thick open cell urethane foam to quiet things down.



In Sport Mode (shifter surround button UP and lit) higher revs are achieved before hitting shift points to suit a more assertive driving style, and the J-Gate feature allows selecting a lower limiting gear for better engine braking in town or on mountain roads. The linear switch module C2N2467 (Find No. 3) begins to get intermittent in higher mileage vehicles and the problem manifests as a nonoperative Sport Mode (and no Sport Mode light), no J-Gate functionality (nor manual gear lights) and sluggish automatic shifting. It eventually resets itself and is apparently the result of the contacts sending anomalous outputs to the TCM, confusing it. If it becomes a chronic condition, the switch needs replacement.

The OEM shifter knobs are pretty pedestrian looking, relative to the rest of the cabin, so check out British Autowood's products. The knob just screws off the lower jam collar. I put the new one on with Loctite 242.



## Driveline

The tubular steel driveline has a Guibo CBC8996 (above, also referred to as a Jurid or Roto-Flex Coupling) at the transmission end and a center stabilization bearing bolted to the guard pan for refinement. The Guibo is good for about 150K mi. The critical balancing of the driveline must not be disturbed and if you change the Guibo yourself, mark all bolt positions, keep them paired up with their specific nuts and don't allow anything to move until each item is restored to its original position. Study everything before disassembly and ensure you have it facing the right way during reassembly. Coat it with DC4 to keep it supple.

## Differential

There is no drain plug and the fill plug is nearly impossible to access on the rear cover of this 3.06:1 differential. To gain easier access to the differential fill plug, empty out the spare tire compartment, remove the high power module and mark a point 2" right of the car centerline and 2" down from the ledge on the front wall. Saw a 2" hole in the wall (and any reinforcing plate). The plug is 1/2" square drive and you will need a wobble type extension to remove it. Conventional wisdom seems to be when the pinion seal starts

to leak, replace it and the fluid as well. Do this service even if the seal hasn't leaked before 125K mi. Cover the hole with a sheet metal plug.

Unless you have a special installation, there were no Limited Slip Differentials installed in these cars. Jack up the rear of the car (to let the half shafts rotate freely for easy access) yearly, grease the four U-joint Zerk fittings and they should last over 200K mi. The joints have a tendency to throw grease, so power-wash the rear axle area periodically.



## Exhaust

Exhaust manifolds are thin wall stainless steel, attached with heat shields, long bolts and spacers to maintain proper tension and compensate for the different material expansion coefficients. This is a low thermal inertia system with closely coupled catalysts being an important part of the design, but their exteriors rust badly. An EGR system was reintroduced in the 2003MY for emissions compliance and is plumbed to the intake via the right side exhaust manifold. The gaskets can develop leaks and the EGR valve pintle sometimes sticks as they age.

There are two C2C7359 (Denso 234-9029 \$70) wideband linear upstream air/fuel ratio sensors (left photo) and two C2C25956 (Denso 234-4798 \$50) conventional non-linear downstream O<sub>2</sub> sensors (right photo). Both are 4wire heated types, their lifetime is typically ~125K mi and they slowly degrade due to catalyst depletion. In so doing the air/fuel ratio sensors report leaner mixtures to the ECM leading to enriched fuel trims in response, producing more carbon monoxide and hydrocarbons, resulting in poorer fuel economy. Downstream sensors ensure that the upstream sensors and catalysts are still doing their job. Replacing the upstream sensors well before end of life is good practice and probably justifies their cost vs wasted fuel. From the right side of the car, locate the sensor connectors mounted on a tree behind the throttle body, against the firewall. You can access the upstream sensors from above, but you need to detach the coolant expansion tank first. The downstream sensors need to be accessed from underneath.

The upstream sensors have gray connectors and the downstream sensors have black connectors. Lift each mated connector straight up off its metal mounting tab. They will pop off their trees with a sustained direct upward force and then there will be enough cable slack to squeeze the locking tab on the end of the each sensor connector and un-mate them. Some have disconnected all sensor connectors at once and reconnected them wrong, so don't be that guy. Remove the sensors using a 7/8" crowfoot socket, lube the new sensor with the included copper anti-seize compound and torque to 33 ft-lb.

The exhaust system is a five box stainless steel design. The pipes tuck up far above the rear axle, making restrictive bends. Replacing just the aft boxes with straight through pipes from Mina Gallery can get you a more aggressive sound. If you feel the need for more, along with a slight performance increase, go for one of the full "Cat Back" systems.



## Electrical

Of all the innovations in the XK8, one bound to go largely unnoticed by owners is multiplexed electronics, similar to the MILSTD1553B differential data bus in modern jet fighters. Though relatively new to automobiles, multiplex technology is thoroughly proven in the aerospace industry, where it has simplified wiring harnesses, reduced weight and improved overall system functionality.

In contrast to conventional systems, where all features must be linked by dedicated hardwired electrical connections, multiplexed systems control the various vehicle functions over a network of interconnected electronic modules operated by low-current switching. The control commands are encoded at each output device, such as a switch or a sensor, to be utilized at a specific destination. This coding technique (in computer terms, a communications protocol) enables many messages to travel over a differential pair of wires, rather than dedicated hard connections between modules.

The shared pathway, or data bus, brings with it an enormous boost in efficiency. With operational information made available across the entire multiplex system, control refinement advances greatly. As an example, communication between the car's various electronic control modules enables the transmission shift program to be altered when the traction control system is activated, helping maintain control under slippery conditions. When the driver switches on the rear window defogger the message is acted on not only by appropriate heating coil control circuits, but is also noted by the engine management system. In this way, increased electrical demand can be anticipated, and engine idle adjusted to compensate for increased drag of the alternator. Many of the control modules located throughout the car require special programming by the dealership if they ever need to be replaced.

The Jaguar Electrical Guide diagrams are quite good and easy to follow. As your car ages, the potential for component failures becomes rather high but, if you follow the diagrams, you are halfway to solving the problem. Robust relays keep switch contacts from having to carry high DC currents, but do add circuit complexity. All relay coils and other similar inductive loads have internal protection to reduce switch contact pitting. Having a knowledge of which relay does what, may help in a roadside emergency and allow you to trade out a failed relay in a critical circuit with a working one from a less critical circuit. As I indicated in the intro, there are discrepancies between the car and the documentation and some relays were placed on their mounts in the wrong positions on my car. Look at the wiring colors to confirm you have identified the correct relay. Brown SPST relays LJA6703AA are the most commonly used, but there are two Black SPDT relays LJA6707AA used in the wiper circuit.

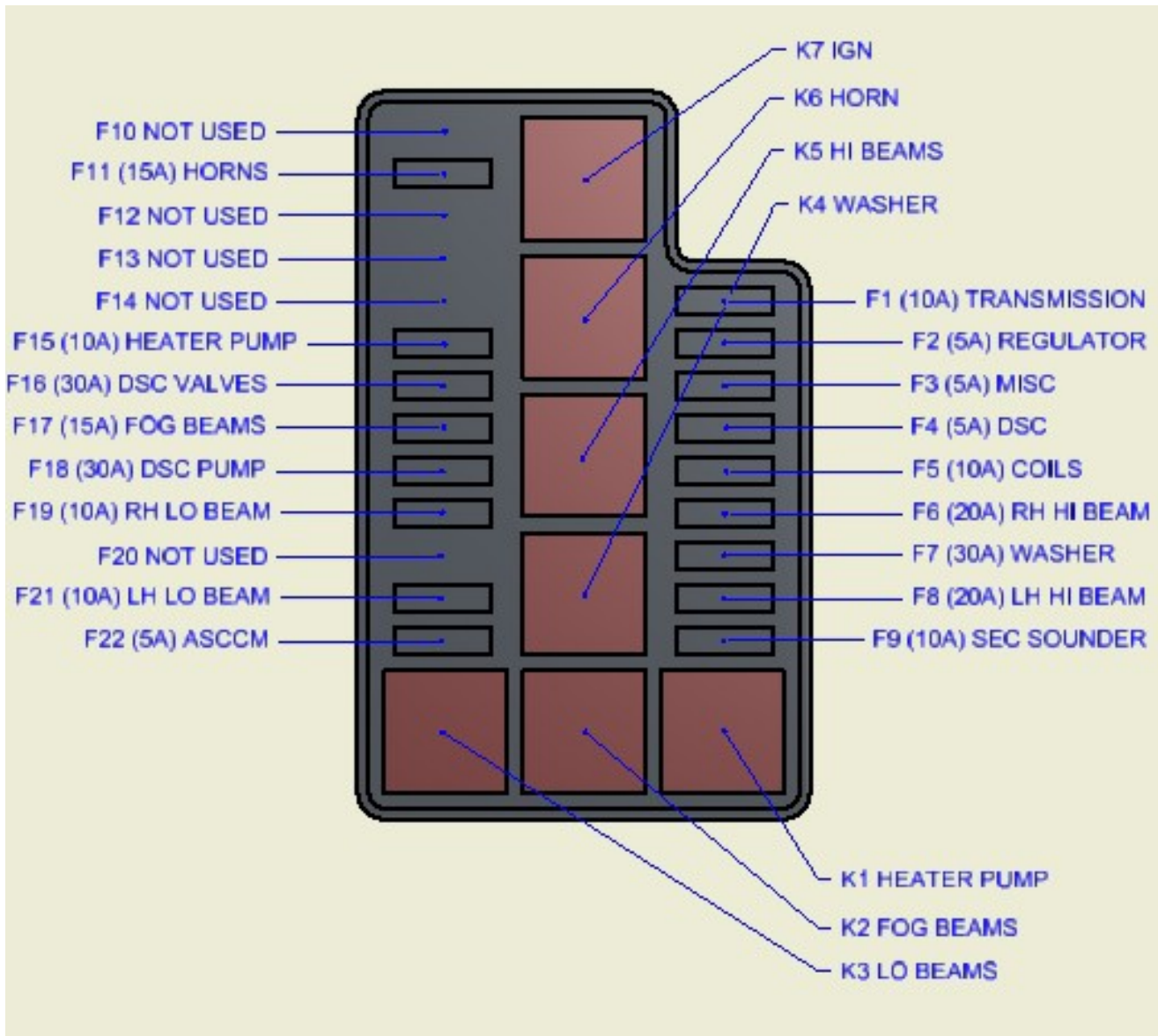

Eng Comp (near DSC)

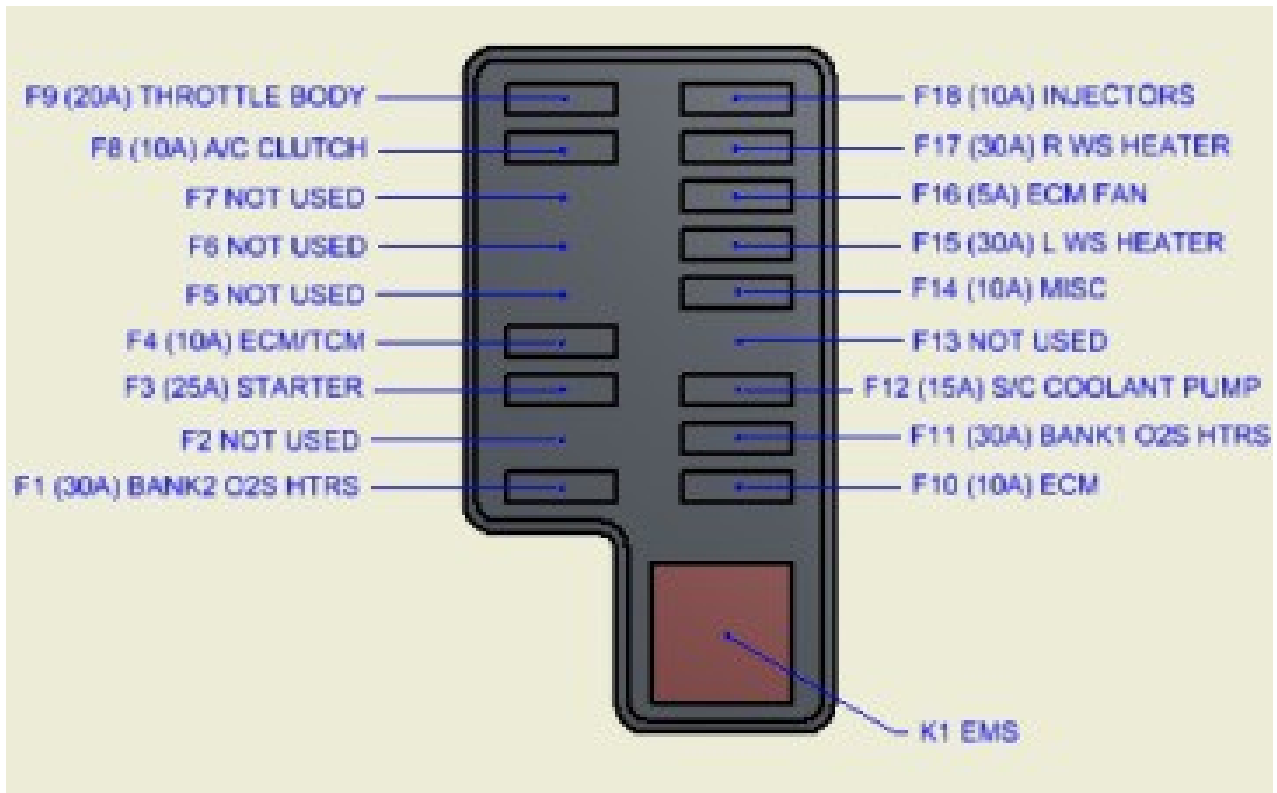

Eng Mgmt (Right Firewall)

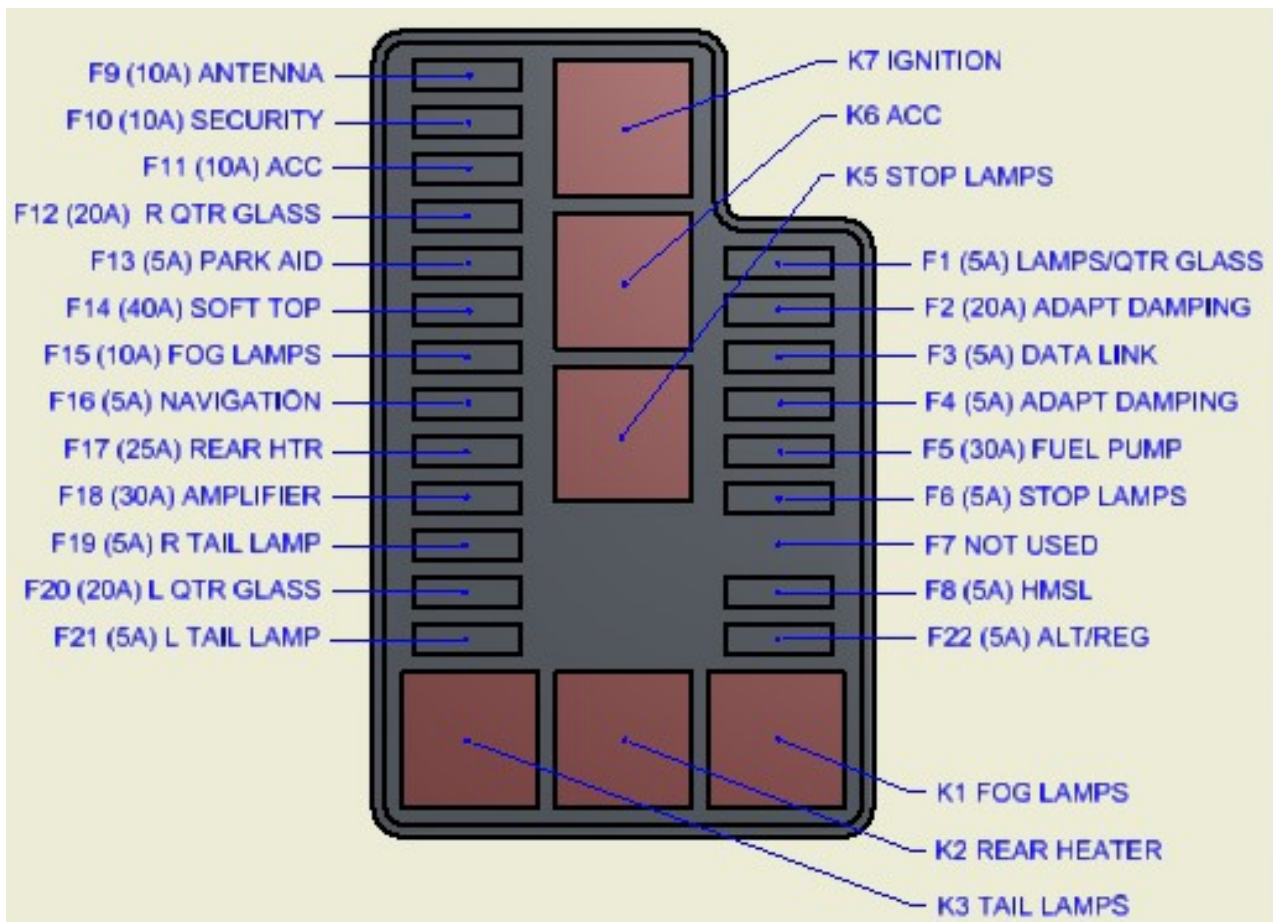

### In Trunk (near Battery)

Windows are frameless and to ensure a quiet interior at speed, Jaguar developed a system to drop the window slightly during door opening and then bump it back up into the rubber seal after closing. Jaguar recommends the battery be disconnected before beginning work on any system and reconnected upon completion, since some circuits are still live with the key OFF. Allow more than 30 seconds between disconnect and reconnect. Anytime battery power is interrupted and restored, the window positions need to be retaught. To do this, sit inside, close both doors, ignition key ON, lower a window and hold the button until you hear a click (a second or so after fully open), then raise the window and hold for another few seconds until you hear a similar click. Open the door to confirm window drop upon open and window rise upon closing of the door. Do this for both windows/doors. **If loss of BOTH window limits keeps occurring, either your battery is nearing end of life or there is a problem with the charging system.** I make sure the car is unlocked, the windows are down and the keys are in my pocket anytime I disconnect the battery. **Before you disconnect the battery, verify that the seldomused manual boot lid key mechanism hidden in the right rear badge still works, so in case you mistakenly close the boot lid, you will be able to open it again.**

There is a tube for venting the flooded cell battery outside. Top off the electrolyte in each cell as needed using distilled water. Equivalent Absorbed Glass Mat (AGM/VRLA) maintenance-free batteries are also available. The alternator C2C19630 contains a replaceable internal rectifier/regulator JLM20187 cooled by forced-air through a fixed tubular Cshaped plastic tube and removable flared plastic duct HJA4477AD (held to the steel cross bar by a single M5 bolt) underneath the car. This duct prevents access to the oil filter, is usually the first item removed, the last reinstalled during an oil change and is often misplaced by careless service personnel. It tucks up above the tubular duct at the rear (it is split on the aft end to allow the center portion to get captured inside the tube) and then clips into the cross bar at the front. If yours is MIA, you should replace it. Every 10°C cooler you can keep rectifier diodes, theoretically doubles their life.

Molded plastic end retainer tabs on side marker lights (and other similar polystyrene or polycarbonate lamp fixtures) stress crack over time. Take them out, fill the area between the tab and body with silicone sealer, let cure overnight, reinstall and this will substantially extend their life. A little EPDM sponge placed under the fuse box cover latches can restore their mojo.

The battery in the key remote is CR2032 and directions for battery replacement are in the Driver's Handbook. Changing it properly DOES NOT require reprogramming, provided you don't push any of the buttons while the battery is out. If you need to buy a new key fob, there is a procedure to program it posted on the Jag Forum. An Inertia Cutoff Switch tucked up behind the plastic panel just forward of the bonnet release shuts off fuel and opens door locks during an impact sufficient to trip it. If it gets tripped, it will need to be re-latched when it is safe to do so. Expect driver side systems to wear out before passenger side due to higher usage.

When you need to replace the power antenna mast LNA4134AA, it is \$20 from [www.antennamastus.com](http://www.antennamastus.com) A068. The chrome antenna nut has very small flats down in the rubber grommet for a wrench and the plastic track teeth face aft.



© Copyright



The turn signal sound and some other chimes are produced by a 2.5" 65Ω speaker LXF2280AA on the side of the steering column facing right. With the top down on a sunny day I have always found the turn signal sound level to be much too soft to be heard and the indicator lights much too dim to be seen. I found a larger 35Ω rectangular speaker and relocated it behind the Adaptive Speed Control and Valet switch holes on the knee bolster to better direct sound at the driver. Use a new Aspirator Grille GJA6100AA\_\_\_ (add interior color code) to fill the empty Valet switch hole.

Inevitably, as your Jaguar piles up the miles, you will get a "Check Rear Lights" alert. If this is the only message you get, check rear lamps IN THE DARK to ensure that they are ALL working, including the middle redundant tail lamps. If you get both "Check Rear Lights" and "Cruise [Control] not Available" alerts, the cause is more likely a faulty Brake Pedal Position (BPP) Switch LJB6420BB (\$150). You can try and replace just the two micro switches for much less money, IF you can find them. They are Cherry DK1GSND1 (Honeywell ZD30S60H02 requires slight modification). The micro switches start to become flakey as they age and their irrational outputs confuse the ECM. Cherry claims an electrical life of 100,000 operations. Ref TSB 206-07.

The BPP assembly consists of a plastic switch module attached to a hanging steel bracket. To access it, remove the driver's seat, the knee bolster and lie on your back. Cut the cable tie on the new switch, remove only the lower nut and slide the plastic switch module free from the top mount. Keep the fasteners, but you can toss the new bracket if the existing one is in good condition. Leave the original bracket attached to the firewall (loosening the mounting nuts from inside the left firewall compartment may be helpful, but DO NOT remove them or you will spend most of the day trying to get the bracket back in its mounting holes). Ensure that the switch ratcheting auto adjuster on the new switch module is set so the inner plastic pawl (at the 6:30 position in the right photo below) rests against its stop. You will need only a short handled ¼" drive ratchet, 8 mm socket and side cutters. Once you are in position under the dash, you will need to reach up through the insulation blanket, find/unplug the cable connector, cut the cable tie, remove the lower nut, depress and hold the brake pedal (starting the engine can get the pedal to initially go lower), lift the plastic module well clear of the lower stud, slide it forward, down and out of the top mount. You will need to again depress and hold the brake pedal as you fit the new switch module into the bracket top mount and over the lower stud. Release the brake pedal and PULL UP/OUT on it all the way to the stop to allow the ratchet to adjust if it needs to. Install the lower nut and tighten. Install the cable tie and plug in the connector.

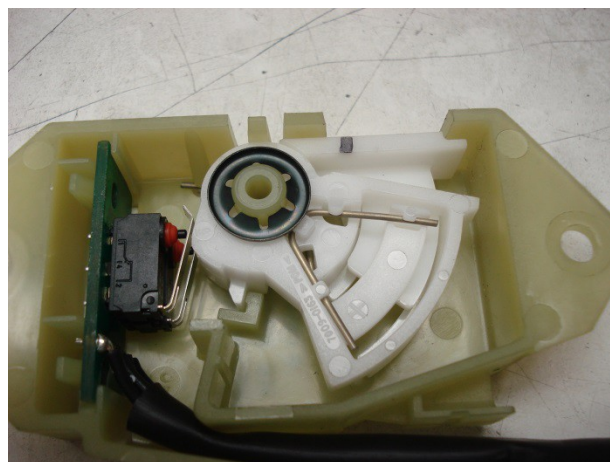

If the charging voltage ever goes out of range, a lot of stuff is either not going to work very well or may get fried as a result of Electrical Over-Stress (EOS). It's hard to know if the modules themselves DO have some internal protection against overvoltage or have current limiting built in. Wiring harness routing must ensure that PVC insulation does not get cut through due to adjacent fixed or moving structures or shorting to chassis ground is likely.

Most connections are made with terminals/contacts that are less reliable than are noble metal (Silver/Gold) plated contacts. Even if the various modules are semi-reliably interconnected, most contain soldered connections. Soldered connections can become unreliable due to both poor initial build quality and the removal of Lead (Pb) from solder formulations as a result of Restriction of Hazardous Substances (RoHS) efforts worldwide. Pb made soft soldered joints ductile and less prone to cyclic stress fatigue. Pure Tin (Sn) solder joints are made at temperatures 30 deg C greater than eutectic solders and can fail abruptly when overstressed. This is not generally a problem for most protected modules, but those in tough thermal and vibration environments (like the engine bay) are at risk.

High circuit sensitivity and system complexity coupled with a lack of requisite trained diagnostic personnel has led to a module replacement mentality (at high cost to the consumer) vs replacement of just the failed component(s). You can send these modules to specialists like [www.modulemaster.com](http://www.modulemaster.com) for repair or as core credit. If you can do some basic troubleshooting, rework and soldering, you can potentially save big bucks by repairing any obvious damage to the module(s) yourself.

Euro color coding as abbreviated as follows in diagrams and manuals.

B is Black	G is Green	K is pink
LG is Light Green	N is brown	O is Orange
P is Purple	R is Red	S is Slate
U is blue	W is White	Y is Yellow

A brown wire with a White tracer would be abbreviated NW. More info can be found at <http://www.jcna.com/library/tech/tech0014.html>

## Suspension

The sophistication of Jaguar's independent suspension design has long been among the most prized of the marque's traits. The suspension system design relies on long-proven components — double wish-bones up front and a control-arm layout at the rear. To prevent road surface noise and vibration from reaching the cabin, suspension components are not attached directly to the body. Inboard ends of the upper and lower wishbones attach to a very light but rigid cast aluminum front cross-member. It has been heat treated and has a Dacromet protective coating to minimize the galvanic couple where aluminum meets steel. The suspension arm bushings are specially tuned to provide a proper degree of compliance when subjected to cornering loads. The forward portion of the engine's weight is carried by tuned hydraulic (oil filled) motor mounts attached directly to the cross-member. Bolts attaching the rubber mounted crossmember to the frame can seize in situ after many years of galvanic action and if you do manage to get them out, they most likely need to be replaced and antiseize compound applied prior to reassembly.

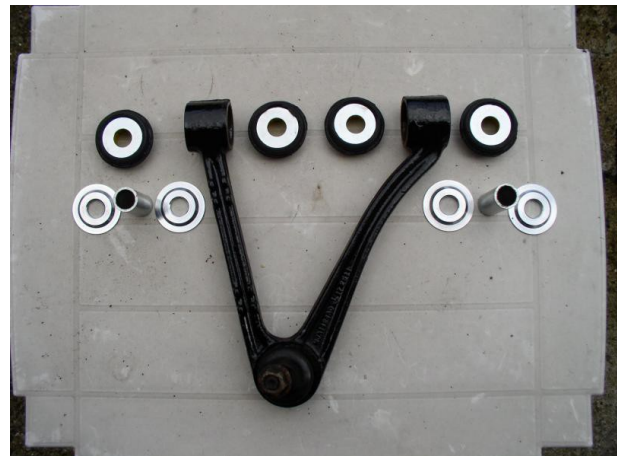
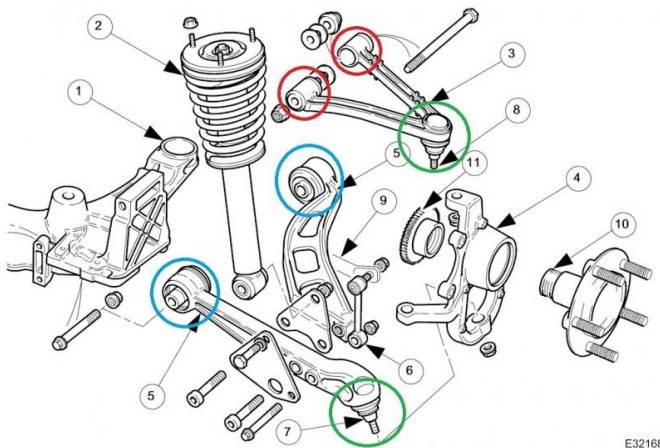

Despite good design and progressive springs up front, low speeds yield a somewhat harsh ride over rough road surfaces such as brick or cobblestone and more so as the components age. An antiroll bar helps control body roll in cornering. The anti-roll bar bushings are simple to replace from above, taking less than 30 minutes. I use Powerflex anti-roll bar and upper wishbone bushings, but make sure you lube them properly with Prothane Super Grease or they are guaranteed to squeak. Ref TSB 204-16. Ensure you pay attention to the position of the castor adjusting shims. Positive castor tips the vertical link axis back (like a motorcycle fork). The default shim location for each side is shown in the line drawing below. Four Washers CAC3533, two .055" [1.4 mm THICK] Blue Shims MJA1467AA and two .035" [0.9 mm THIN] Red Shims MJA1467BA are used on each side. The castor for the right wheel is set at a slightly greater angle than the left (for left hand drive in the US). Newer upper wishbones are 2mm shorter than the originals, providing a fixed ~1° negative camber. The brake line/wheel sensor harness brackets get in the way of the washers and should be bent down or kissed off slightly to improve clearance.

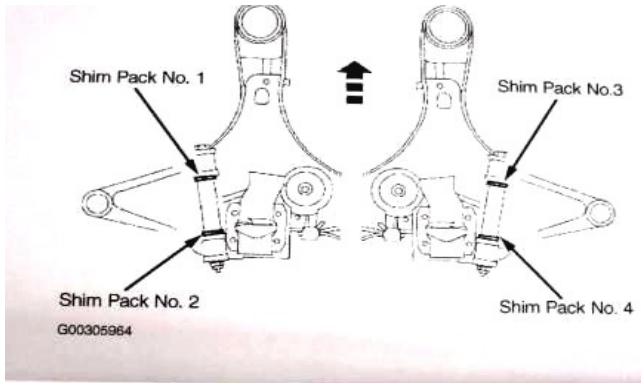

**Shim Pack Application (1)**

Application (2)	Contents
Shim Pack No. 1, Left Front	2 Thick, 1 Thin Shim
Shim Pack No. 2, Left Rear	1 Thin Shim
Shim Pack No. 3, Right Front	1 Thin Shim
Shim Pack No. 4, Right Rear	2 Thick 1 Thin Shim



The upper front shock mounts MJA2170BD each have both large and small sponge rubber isolator doughnuts that take a compression set and harden over time. Improved OEM parts are around \$190 a pair. Changing out the shocks takes about 90 minutes per side. You will need a set of spring compressors and it helps to have 3 ratchet straps and a bench vise to stabilize the bottom of the shock while you work on it. If you want the nut covers that were omitted from the newer cars, they are NJA3975AB large and NJD3975AB small. Make sure you can get the upper shock shaft end nut loose from the getgo. The Great Neck 25284 socket fits the end of the shock shaft, but this portion of the shaft can just twist off if the original nuts were overtorqued. In this case a carbide disc is needed to slice the nut. The MJA2150BA shaft bumpers rot out and will likely need replacement.

Front wheel bearings MNC1830AA (SKF BAH0028) are a robust sealed double cartridge type greased for life. DIY replacement is possible as long as you have access to the special tools needed. Some merely replace the entire vertical links (Find No. 4 in the above line drawing) rather than wrestle bearings out.

The rear suspension shown in the line drawing below reduces a natural tendency of the car to squat under acceleration. Like the front end, the rear suspension utilizes a control-arm design, with a coil spring and damper combined into a single unit. Springs are seated directly on the transverse lower wishbone, not the damper, which reduces friction for better ride comfort and noise isolation. The halfshafts serve as the upper suspension links.

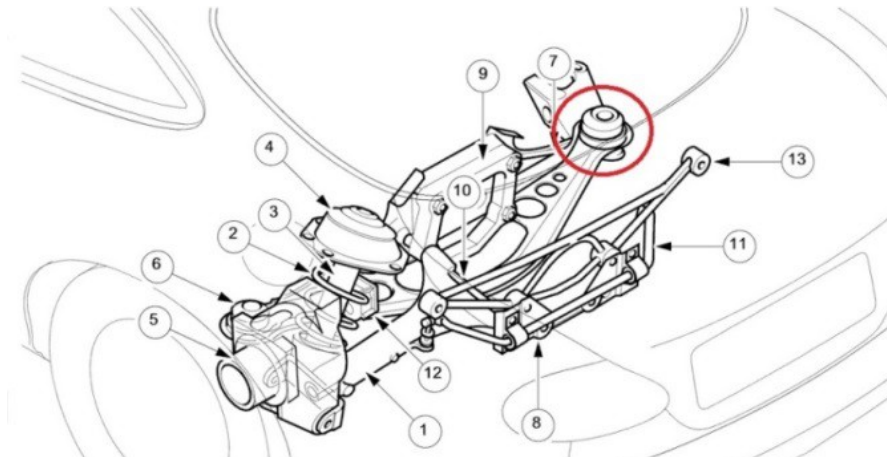

The entire rear suspension is mounted to a stamped steel cross-member, bolted to the body through elastomeric bushings tuned to isolate road harshness. In addition, the lower control arm pivots allow some deflection toward the rear when the wheel is subjected to the sharp impact of a pothole or bump. An antiroll bar helps control body roll in cornering. The bushings are simple to replace from underneath, taking less than 30 minutes. Due to limited space, a slim spring compressor like Sir Tools ST9050 is needed for rear end damper work. Rear wheel outer CAC6333 and inner JLM21053 bearings are not sealed for life and will likely need replacement before 200K mi.

The front of the car is pretty low (~5 inches at the front bumper fascia on my car) requiring you to adjust your approach angle when negotiating driveways and gutters, never taking them straight on. A 45° approach/departure with no braking dive is the best practice, or you will certainly end up scraping the underside of the front bumper fascia. I end up sanding and repainting the underside of it at least once a year. For paint issues I use a Meguiar's K2000 Mirror Glaze Unigrit sanding block (2000 grit). Before using, soak the sanding block in water for a day until it sinks to the bottom.

I prefer to jack each front wing by positioning the jack cup over the side brace bolt just behind the front wheel arch, although the entire front end of the car may be safely raised using a floor jack bearing on the steel cross beam directly beneath the radiator. It is best to place a wood block on the jack cup so as not to mar the bearing surface. The entire rear end may be raised by bearing on two bolt heads at the rear cross brace anchor points.

## Steering

The rack and pinion steering system uses ZF Servotronic components. Jaguar's advanced steering system incorporates speedsensitive variable power assist and a variable steering ratio. Speedsensitive power assist delivers full hydraulic boost at low speeds for easy parking but, as vehicle speed rises, assist lessens to give a well-weighted, confident feel to steering at highway speeds. Due to high assist at low speeds and wide front tires, driving slowly on rippled/scalloped road surfaces results in some tramlining, but you can't have it both ways. While some less sophisticated systems provide variable assist by cutting flow of fluid to the steering rack itself, their effectiveness is hampered by a need to maintain sufficient flow for emergency evasive maneuvers at high speeds. Using the hydraulic reaction principle to vary steering effort enables both worldclass steering feel and power assist that is always available regardless of speed.

To further refine steering feel during straight-ahead highway driving, the steering gear valve incorporates a positive center feel torsion bar. As the name implies, the torsion bar twists a slight amount in operation, effectively programming an on-center position into the action of the steering valve at small steering angles, improving stability in conditions such as crosswinds. When the steering wheel angle exceeds a predetermined amount, the torsion bar reaches the end of its travel and control of assist levels is assumed by the Servotronic system. Variableratio steering: the steering rack is a design in which the rate of road wheel movement quickens as extremes of wheel travel left and right are approached. This makes parking less tedious yet provides appropriate levels of assist — not overly sensitive to slight steering wheel movement — for good stability at highway speeds.

Steering column tilt and/or reach motors often don't work properly. Here is what worked for me.

1. Drop the dash bolster from under the steering column and access the lower/reach motor.
2. Cut the WU wire, solder in a 2.7K $\Omega$  series resistor and sleeve/tape.
3. Reassemble everything.
4. Set the column movement switch ON, hit the memory buttons to reactivate the circuitry and reset memory positions.
5. There is now a momentary delay in reach motor retraction that I find desirable.

## Brakes

The brake system uses an Ate (Alfred Teves Engineering) Continental MK25 4-channel Dynamic Stability Control (DSC) unit in a split front-rear arrangement and requires DOT4 fluid. For some reason the rubber bellows inside my reservoir cap swelled up, so I replaced it with a flat one made of 1/8" thick reinforced silicone rubber sheet. The active brake booster uses braking pedal force and rate to modulate wheel braking forces. Unfortunately the OEM single pot single acting front calipers are somewhat anemic for spirited braking. I use Centric Power Stop drilled and slotted discs with semimetallic pads. Limits on rotor wear are 26 mm for the front and 18.5 mm for the rear. Relube the caliper pins with high temperature ceramic grease.

Speedbleeders are available to make single person bleeding much easier (SB8125L-SS in front and SB8125SS in the rear). They also sell a tubing equipped plastic recovery bag (like an IV bag) to handily catch expelled fluid. Jaguar recommends the following bleed order: LF, RF, LR and RR.



Wheel speed sensors are conventional Hall Effect types and each connects to the main wiring harness with a short link cable, each with differing length and wire colors. The actual sensors are very longlived but the front link cables get flakey because steering requires them to flex so much. The DSC system threw DTCs C1155 and C1233 and I could feel a shudder in the brake pedal when the left front wiring harness LJG3410FC was first to go at 100K mi. The right front harness is LJG3410AC. Remove each front wheel for better access and replacement is a 30 minute job.

Fuses F4, F16 and F18 in the Engine Compartment Fuse Box supplying power to the DSC black box are covered with orange plastic caps, to prevent their mistaken removal and leading to a braking/safety issue. All connections from the DSC box to the hydraulic block are inductive, so it just unbolts from the block. This is a simple matter on some cars, but in our case the hard fluid lines are formed in such a way that it is impossible to remove the box without undoing the hydraulic lines. The harness connector has a sliding plastic end bar to seat and lock the connector in place and it needs to be pried out from the end to disconnect the harness. DSC requires that all four wheel sensors be functional or the system shuts down and turns on the DSC warning light. Some have experienced circuit board solder joint fractures at the two large terminals (with the DSC system throwing DTC C1095) which is easily rectified by resoldering using 63Tin(Sn)/37Lead(Pb) solder. Gus at [www.jagrepair.com](http://www.jagrepair.com) recommends sawing a 1" hole in the notched corner of the cover providing easy access to the large pin solder joints (shown in the photo below) most prone to stress cracking. Then just RTV seal a rubber or plastic plug in the hole.

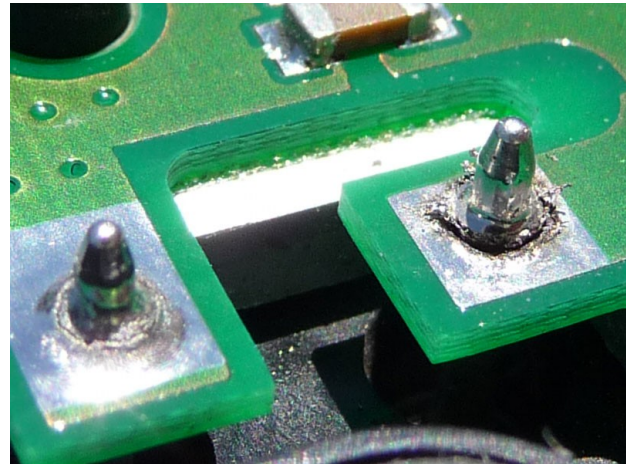

The DSC system reduces drive torque to the wheels by controlling throttle position, ignition timing and fuel supply to the cylinders. An optional TRAction Control (TRAC) system adds brake intervention to slow a spinning wheel. Wheel spin is detected by anti-lock brake sensors after comparing information supplied by all four wheelspeed sensors. Both systems may be manually canceled by pressing a switch above the center console to power out of deep snow or when using tire chains. The Automatic Stability Control (ASC) feature is operational at all speeds to enhance traction in slippery conditions. When wheel spin is detected, the antilock electronic control module calculates an engine torque reduction that won't cause tires to slip, based on information from the vehicle's Controller Area Network (CAN). First, throttle angle is reduced, but because the effect of this action is not instantaneous, two further measures are taken. Ignition timing is retarded and fuel to the cylinders is cut off until proper throttle position is reached.

## Wheels/Tires

Jaguar could easily have done a better job of either plating or painting the wheel hubs, as they become quite a rusty mess after only a few years of trapped moisture. I did the brake job at 100K mi. Use WD40 Rust Penetrant spray and a puller as needed. Before reassembly, hit them with a wire brush and a light coat of black Rustoleum. Wheels are hubcentric so put grease on the centering bosses to keep them from sticking to the hubs and a drop of oil on all stud threads. Some have had trouble with the two-piece lug nuts (nut and a crimped on dress cover) spinning or coming apart, so make sure that you can get them off in a pinch when you need to.

Extra room for wider tires and/or wheels with greater offset was provided in the wheel arches. Once you have settled on wheels and tires that you like, you may prefer to restore tires to a more optimum position. Moving them out will improve cornering and aerodynamics. 20 mm thick H&R 4085738 hub centric wheel spacers work well with my Atlas wheels. Worn ball joints can exacerbate tramlining, since the power assisted steering is already so light to the touch.

OEM chrome wheels experience plating separation over time, leading to slow escape of air from the tire bead seating area. Ref TSB 204-06. You need your tire guy to inspect plating in and around the bead seating areas during tire mounting and advise you, **however this is not a good time to find out you need a new wheel**. Another way of assessing their condition is to examine the perimeter of the center growler badge. If you see chrome separating (a raised area) in this region, then chrome in the tire bead seating area is likely compromised. Newer plated wheels do not have this problem and may be recognized by the presence of grey epoxy paint instead of chrome plating in the bead seating areas. I have found the factory recommended rear pressure of 34 psig too high for uniform wear on the rear tires, so I keep them at 32 psig all around. Make sure that your tire guys do a good job of removing the balance weight adhesive residue and crap from your wheels before they attach new weights or they may sling off. A toothbrush and some Coleman Lantern Fluid (Naphtha) will do the trick. Also ensure that they pay attention to any High Spot marking on the tire. Ref TSB 204-18. Be aware that Lead (Pb) wheel weights were discontinued years ago for environmental reasons without much fanfare and it now takes three times the number of Iron/Steel (Fe) or Zinc (Zn) weights to do the same job.

OEM wheel center caps supplied on my car looked pretty cheesy. I bought nicer looking replacements MNA6249AB and there are others available in different colors if you prefer.

My car came used with Hankooks, but I like Michelin Pilot Super Sport tires much better. Their rather straight cut tread does contribute to some groove wander, especially when new. Whatever you put on, the rear set will get you ~20K mi, depending on road surfaces and how hard you get on it. The front set will likely last twice as long. Low profile tires make wheels prone to curb rash if you are careless. If you need to buy new wheels, the aftermarket is your best option. Many of the single piece OEM wheels are still available from Keystone dealers at a substantial savings. Remote wheel pressure sensing devices are available to retrofit to your wheels, but there are also inexpensive visual indicators that allow you to easily check to see that your pressures are correct on your walk-around.

## **Windscreen Washers/Wipers**

Wipers are 21" and have tubing for the arm mounted nozzles. The tubing seems to be of good quality, but won't last forever, so watch it. The passenger wiper arm pivot is in the center of a very strong low pressure area creating a vacuum/venturi effect near the rear edge of the bonnet at speed (like blowing across an open bottle). The faster you drive (above 90 mph) and the longer you drive fast, the more it wants to suck the black plastic cap GJA8966AB up and off of the wiper arm recess. I lost two before I decided that a little weather-stripping cement was needed here. If you lose the cap, the nut and shaft will rust due to exposure and a tendency of the recess to trap moisture. I replaced the nuts with stainless steel.

The washer fluid system lower filler neck-to-reservoir joint is a poor fit and can leak as the rubber grommet dries out over time. Remove the unit from the left front wheel arch, disassemble the reservoir to filler neck joint. Remove the large rubber grommet and clean everything in the vicinity of the joint well with Isopropyl Alcohol. Get some silicone aquarium sealant (it has better adhesive properties than some of the other caulking silicones) and butter up both the grommet outside groove and inside surfaces with sealant. Reassemble the grommet, neck and reservoir then reinstall in the car to cure in situ.



Windshield washer fluid not containing sufficient alcohol (Methanol was removed from them years ago to render them less toxic) can foster bacteria growth in warm to hot conditions and specifically Legionella bacteria can spread as the mixture is aerosolized during use. Always add 2 to 3 cups of denatured or isopropyl alcohol per gallon to all washer fluid to fortify it, cut road grime better and improve resistance to freezing during winter.

## Convertible Soft Top

The soft top fabric and liner are attached to a folding aluminum framework engineered to provide a low stack height. You can operate it easily, even inside a garage with a fairly low ceiling. Due to the rear space needed for stowage of the soft top and actuating mechanism, the rear seat will barely hold a small dog. Operation requires pressing and holding a momentary rocker switch on the center console until a chime indicates first the start, then about 20 seconds later, the completion of soft top close or open action, while traveling at up to 10 miles per hour. Latching, unlatching and rear side window operation are all automatically sequenced, but you must continue to hold the button down beyond the chime for the entire erection cycle (including windows) to complete. When using the key lock method to lower the top, door windows are driven to their fully down positions. Benign crackling and creaking noises come from the soft top latching area as the car body flexes over bumps.

Here in the states it is common for hydraulic hoses to leak or burst over about a 10 year period, leading to the dreaded "Jaguar Green Shower" from the windshield frame/overhead console. This is virtually unheard of in the UK, so heat is definitely a factor here. If you see a drop of green fluid hanging from the overhead console you need to take immediate action to replace the hoses.

Two methods of lowering peak pressure in the system have emerged, but they only mitigate the problem for a time. The left photo below shows the two 0.1 Ohm 50W series resistors voltage dropping method and the right photo from Gus at [www.jagrepair.com](http://www.jagrepair.com) shows the LSI pressure relief valve method. Use only Pentosin CHF11S (green synthetic fluid) in these pumps and if you have any other fluid (early models used a different brown fluid that became gelled in the lines with heat over time), it must be completely purged/flushed and replaced with CHF11S or bad things will happen. Soft Top hydraulics are driven by a PowerPacker brand pump spiking to 1600 psig and it is the OEM Parker hose PVC jacket that breaks down over time leading to leaks.

Much higher quality non-OEM hoses rated >20,000 psi are available from Top Hydraulics Inc. The hose replacement job is tedious but not terribly difficult and takes ~8 hrs (I did it over a few days) to get interior items apart, hoses unclipped/routed and everything reassembled. It can be a little aggravating at some points, but can be done, if you pace yourself. Jaguar shops want a lot of money to do the job, so DIY will save you big bucks. You will need to replace the left door tread plate fascia and some fluid, but pretty much everything else is reused. If you replace the hoses in this manner, you need neither of the pressure lowering fixes mentioned above.



[www.jagwrangler.com](http://www.jagwrangler.com) has a spiffy modification installed in the driver's door allowing you to remotely control soft top operation using the headlamp button of your key fob remote. Certain areas of the soft top inner liner (probably a polyester material with the look and feel of a light fleece) will get sooty along with all of the rear seat surfaces (same as the radio antenna) if you are driving around a lot with the top down. I use a combination of 70% Isopropyl Alcohol on a microfiber towel and a little steamer vacuum cleaner. I modified a VAPamore MR-50 to allow both the steam generator and vacuum to run simultaneously.

Servicing of soft top components is done by [www.tophydraulicsinc.com](http://www.tophydraulicsinc.com), [www.cabrioletroofhoses.com](http://www.cabrioletroofhoses.com), [www.convertibletopguys.com](http://www.convertibletopguys.com) or [www.topsonline.com](http://www.topsonline.com).

## Interior

The OEM separate headrest type seats were a poor choice for a GT car and, though adequate to the task of driving, they fail big time in the cornering department. Bolsters are not shaped to retain your bum or upper body in the seat, so you end up sliding from side to side. They have a tendency to develop annoying squeaks/creaks over time, requiring you to apply some silicone spray up, in and around the bolsters, seams and folds. There is also a fix that adds clips to the seat risers to reduce end float. Ref TSB 91007a. The seat control modules mount under the front of the seat base, and after years of seat flexing, their plastic lids crack. There is a replacement lid/cover C2N3565. Ref TSB 419-17. When replacing these it may be a good idea to put rubber washers between the lid and bracket, use Loctite 222 on the studs and tighten the nuts only snug. Be sure to transfer the label containing the programming info from the old cover to the case. The range of seat motion is somewhat limited for long legged drivers and the seat can only go back as far as the rear seat bolster allows. There is just enough room in the foot wells for my size 12½s. With the top up, there is little headroom and I'm 6' 2" with an extra lumbar vertebra. I have the seat base all the way down both front and back.

Headrest drive cables can be troublesome, but fellow Pastafarian Reverend Sam, has kindly made TSB 501-58 into a YouTube video, describing correcting sheath length and allowing the internal cable to fully engage the drive spindles. Pull the internal cable out and use a Dremel type tool with a carbide cutting disc to girdle the sheath somewhere near the middle of its length and use a good quality ½" starting diameter semi-rigid wall heat shrink tubing having a meltable adhesive inner wall (meeting AMS23053/4105-0) to rejoin it (don't use duct tape) and this fix will last the life of the car. The headrest drop feature is controlled by a micro switch on each seat frame. The seat side release lever allows the seat back to tilt forward, actuating the micro switch powering headrest retraction into the seat back. When the seat back is returned to its normal [position](#) the headrest seeks its pre-programmed position. These micro switches are snapped onto the seat frames facing the driveshaft tunnel and can be easily dislodged by careless vacuuming of the interior. The seat back latch pins can be improved by placing some .610" ID/.710" OD black PE drip irrigation tubing over the shank. The driver's seat lumbar bladder was positioned wrong for my back, but that was easily remedied by disassembling the rear of the seat back and changing the tie wrapped height of the bladder relative to its rubber mounting web.

The cup holder is completely laughable, but a rebuild kit GNA7692AB is available. Ref TSB 501-06. The center console armrest cover foam gets compressed, the leather starts to ripple and the whole thing begins to look shoddy over the years. Better (crosslinked high density) Ethafoam is probably called for. Rev Sam's got this and some other DIY activities, covered in YouTube videos too.

The molded rubber weather-stripping on the doors can split where the window glass edges exit at the front just above the side mirror and at the rear just above the door latch. Cost of replacement is significant and installation laborious. At the front, trim off the split sharp corner and smooth it into a more rounded corner with a Dremel tool sanding drum. For the aft split, get some Permatex 80338 Black Rubber Sealant and thin it with Toluene as necessary. Clean and scrub the repair area well using Acetone and a Scotchbrite pad to get any release agents off and give the surface a little tooth. Tape the back side of any split areas together before you start. Using an acid brush or airbrush, apply the sealant in multiple thin wet coats. Let setup overnight and reapply as necessary.

Window track adjustment screws are accessible without removing the door panels (they are hidden behind the puddle lamps and speaker grilles). The rear quarter glass adjustments are far less accessible and should be made only after the front glass is set correctly. The rear quarter glass leading edge rubber doesn't always seal well with the door glass and some wind noise is audible. Ref TSB 501-52. Lube the window tracks with 3M Silicone Paste. The top rear door panel plastic casing brackets often break as a result of slamming doors and are easily replaced. Ref TSB 501-57. The door latch mechanism internal micro switch contacts degrade over time. If only one of your doors fails to bump the glass up upon door closure and you know your battery is strong, it may be time for a new switch C2N1908. Ref TSB 50154. If both doors start doing this, then your battery is near dead. This may show up more in winter, because your weak battery is further stressed by cold temperatures.

I like dash mats for my cars and Cover King makes a nice velour one. Having a dash mat fly up in your face on a convertible at speed would be a real bummer, so use PermaBond Contact Cement or Gorilla Glue to bond the Velcro anchors down. The Pilkington (Triplex) windshield glass is soft and pits instead of cracks from road gravel hits.

The door check arm attachment to the body shell can shear back and forth creating a snapping sound. Jaguar hasn't shakeproofed the bolt and they loosen in service. Remove the bolt, reinstall it using some Loctite 242 and retorque securely (about 5 ft-lb [60 inlb]).

Vanity mirror lamps are not wired through their hinges, so they only work with visors stowed in their clips.

## **Restraints**

Extensive safety considerations are engineered into the XK8. The onboard active restraint system constantly assesses occupancy/position of those in the cabin to optimize deployment of airbags under a wide variety of conditions. Dual seat bolster airbags are provided for both driver and passenger, along with pyrotechnic seat belt pre-tensioners to take up seat-belt slack during impact.

## Climate Control

The heater matrix (octopus) hose assembly MJA6728AC can be the source of leaks. This hose taps into engine coolant flow and redirects some to the heater core. Check valves (one in the octopus hose and one in the heater core outlet line) prevent backflow. IMO Jaguar engineers should not have located the Norma Push and Seal R20 plastic connector on the feed line where they did, as it boils between the heat from the Bank 1 catalyst and the EGR pipe, leading to internal seal degradation. Initially an occasional coolant drip just boils away on the catalytic converter leaving no trace. You may smell coolant when you shut down the engine, but never find a puddle. Pressure testing the cooling system cold at 15 psig for several hours with a clean dry shop towel under the connector can ID this problem. The internal Oring seal is a proprietary odd size 19.6 mm ID X 3.6 mm CS Seal Volkswagen sells (P/N N90316802) if the hose and connector are otherwise in good condition.

Releasing the R20 connector is not complicated, but if you break it, the \$200 octopus hose assembly requires several tedious hours to replace. Working with a cold engine, place a large plastic tub under the area. Merely push down on the ribbed tab, rock it slightly back and forth and slide the entire tab and outer sleeve TOWARD the hose. Once it is fully retracted, grip the hose, rock it slightly back and forth, pulling until it releases from the steel outlet pipe AJ83928. While you have it apart, ensure the pipe is absolutely clean and smooth or IT WILL LEAK. Some blue firesleeve 7569K16 from McMasterCarr placed over the hose before reassembly will provide some heat protection. Two other hoses in the heater core plumbing are intentionally flattened in the curves, so don't freak out when you see these.



The auxiliary pump MJA6710AA and control valve MNA6711AC divert some coolant to the heater core. The life of this pump is around 100K mi. The motor case and shaft are a poor fit and binding of the impeller against the divider plate can occur. Just because the motor is turning doesn't mean the magnetically coupled impeller is pumping. When power is applied to the control valve, it closes. The pump and valve can be tested in situ, but access to the pump for removal is difficult, as it is bolted up from underneath. Eurton Electric 33E brushes fit these motors if you shorten them by .125". You can try to find a similar pump or you can buy a new OEM pump for \$500. The YELLOW wire is +12VDC, so don't reverse the polarity if you power it on the bench or you may burn out the internal catch diode. As long as you have the motor apart, verify the diode has a least a 10:1 forwardto-reverse bias ratio. Pump fresh water through it and back-flush the heater core at a safe 14.5 psig (1 bar).

The Climate Control System has an internal diagnostic mode. Begin with Key IN, Ignition OFF:

1. Press/Hold RECIRC and AUTO buttons as you switch Ignition ON and START engine, then release buttons. Display will flash. Verify all display elements are functional.
2. Press AUTO button and read code. If Zero, there are no stored fault codes. For a listing of codes refer to [www.gusglikas.com](http://www.gusglikas.com).
3. Press FACE button to scroll through any remaining codes.
4. Press FACE and HEATED READ WINDOW buttons together to clear each fault code in turn.
5. Press RECIRC to perform actuator check.
6. Press FAN/OFF button to exit diagnostic mode.

The most common fault is 11. On the driver's dash underscuffle, close to the console, there is a little plastic grille behind which sits a thermistor and aspirator/fan for the climate control system to reference. When this gets crudded up, the climate control system can't accurately sense temperature of the interior. While it's apart, this would be good time to power up the fan with 12VDC to ensure it still works. Clean the thermistor with Isopropyl Alcohol and reassemble. There is no OEM pollen microfilter under the bonnet of LHD XK8s.

The A/C is conventional and the low pressure charging port is up near the firewall. Always hold the can upright (and turn sideways briefly to agitate) to introduce just R134a vapor/gas into the line (not liquid) or you can damage compressor seals. Some charging hose assemblies require the use of a DVA1 adapter for the newer nonpiercing auto-shut-off cans.

## Engine Bay Heat Soak

There is rarely enough room to easily access some system components because the engine bay is largely full of, well ... engine. Heat produced by the engine and conducted through the attached aluminum alloy structures destroys electronic components and needs to be forcibly ejected, so prolonged "stop and go" traffic should be avoided. During cruise the engine bay temperature is just slightly above ambient, but rises to >200 deg F right after shutdown. All the waste heat bakes into surrounding structures including the fuel rail, wiring bundles, hoses, plastic and rubber parts and can stay that high for about an hour. The electronically controlled radiator fans don't run at all when the engine is first started cold, run slowly (electrically connected in series) when coolant temperature reaches 190°F and run at full speed (electrically connected in parallel) at a coolant temperature around 204°F. In my opinion, Jaguar should have louvered the bonnet on all XKs and allowed the fans to continue to run after shutdown to combat the heat trapping tendency.

## Cleaning/Protection

Keep all hoses, and for that matter all rubber items (except the serpentine belt), well coated with a good silicone oil spray for longest life. I recommend using industrial food grade low viscosity spray CRC 03040 (Fastenal carries it) for large area coverage and Easy Rider RT630A (paint ball aficionados use it) for coating small bushings, because it is thicker and clings better.

If your car is a daily freeway driver, you need to protect the front end against road FOD. The Front Bonnet Protector C2S4496 (black naugahyde bra) was never reconfigured for front end changes of the 2003MY. I trimmed it for the lower intake and had a local auto upholstery shop re-edge it. The newer grille is deeper, a different shape and the plastic clips no longer reach, so you must make your own attachments to adapt it. You will also need to make some loops (I formed some of .032" dia stainless steel aircraft safety wire) to hold the corners up and back using the front fir tree clips of the wheel arch liners as anchor points. Clear protective film bras are also available. I never liked the hokey bucky beaver teeth (for covering the bumper energy absorbing aluminum extrusions and mounting the front license plate) or the chrome splitter vane in the grille opening, so I removed them, painted the extrusions black and covered their forward facing surfaces with black non-skid strip.

Convertibles tend to get sooty inside with the top down. I use Armorall leather wipes to clean, then Surf City Garage Voodoo Blend Leather Rejuvenator to treat leather. Outboard piping on the driver's seat bolster and the surrounding area will get rubbed raw by your bum long before any other leather surface wear is apparent. I use Leather Colourant restorative dye from Furniture Clinic to fix surface flaws and worn areas in the leather. New seat skins are available from GAHH and [www.topsonline.com](http://www.topsonline.com).

Other protectants may be needed in different climates. Noxudol 750 anti-corrosion treatment cavity wax should be applied on and/or into all places you can get to with the included snaky hose subject to moisture ingress and road salt effects. Remove plastic front wheel arch liners for access and apply wax in these areas too. If you can get the car up on a lift, look for lower areas prone to moisture or rusting and apply it (just don't get it on braking surfaces or items that must move freely without binding). The steering linkage U-joint knuckle in particular has a tendency to rust, so wax it regularly.

For soft top external cleaning and protection, I use Raggtopp to clean and treat the fabric twice a year. Any little nicks in the paint get a little airbrush attention with Automotive Touchup brand paint. I also use those little foam ended touchup brushes to fill dings. A Meguiar's K2000 Mirror Glaze Unigrit Sanding Block dresses and levels rough areas and I have a Porter Cable 7424XP for the finishing work. I clay the car every other year and apply Mothers FX SynWax. I don't always treat the fuel injection system, but when I do, I prefer B-12 Chemtool. Stay clean my friends. There isn't much exposed plastic, but the best plastic treatment I've found is Meguiar's brand. For the tires, I use Turtle Wax gel.

Along the insides of the engine bay are cable routing troughs that collect all kinds of muck, so blast them clean with a pressure washer periodically. The plastic lower body sill rails undershoot the wheel arches, creating ideal gravel trapping opportunities and the front splash guard tends to fill with small pebbles and leaves. Clean these areas regularly.

## Lighting

My car has halogen headlamps and they are fine. Headlamp lenses are non-safety glass, quite sharp when shattered and prone to road FOD damage. Use the XPEL protective film applique kit H3304A or you may soon be buying a \$260 lens (left LJA4651BA, right LJA4650BA). The kit has six pre-cut .035" thick pieces to cover all the individual headlamp glass surfaces including fog lamps and the washer nozzle crescents.



Halogen lamps are available in various versions and should always be used in pairs so the color and intensity of beams on both sides match. Many lamps are available from Sylvania as Long Life (LL suffix) incandescents or from other manufacturers in LED equivalents. It's a personal thing, but I find cars with LED brake lamps too startling, so I prefer incandescent brake lamps. Some have found the LED versions of interior lamps to be inferior and/or undimmable. The large bulb assemblies in the instrument cluster provide the gauge illumination and the small bulb assemblies are the turn signal, message center and high beam indicator lamps. The small bulbs also fit the lighted switches above the climate control. The instrument cluster airbag and headlight indicators are PCB mounted bulbs and the remaining instrument cluster indicators are PCB mounted LEDs. It was nice of Jaguar to provide a redundant tail lamp in the center position of the rear fixtures running only the 5W filament. In a pinch this bulb can be swapped for a failed stop lamp in the outside position.

<b>Position</b>	<b>Ref P/N</b>	<b>Description</b>
• Front Lo (Dip) Beams (2) outer	H1	55W Halogen (STR)
• Front Hi (Main) Beams (2) inner	9005	65W Halogen (RA)
• Front Running (2)	2825	5W (T2 Wedge)
• Front Turn Signal (2 YEL)	1056F/7507A	Y21W (Bayonet)
• Front Fog (2) lower	H1	55W Halogen (STR)
• Front Side Marker (2)	2825	5W (T2 Wedge)
• Door Puddle (2)	2825	5W (T2 Wedge)
• Glove Box (1)	3893	4W (Bayonet)
• Instrument Cluster Large (4) upper	LJA4390BA	3W blue (PCB)
• Instrument Cluster Small (4) lower	LNA5180CA	1.25W blue (PCB)
• Interior Foot-well (2)	2825	5W (T2 Wedge)
• Interior Map (2)	2825	5W (T2 Wedge)
• Rear Side Marker (2)	2825	5W (T2 Wedge)
• Stop and Rear Running (2) outer	1077/7528	21W/5W (Bayonet)
• Rear Redundant Tail (2) center	1077/7528	21W/5W (Bayonet)
• Rear Turn Signal (2 YEL)	1056F/7507A	Y21W (Bayonet)
• Back Up (2)	1057F/7506	21W (Bayonet)
• Rear Fog (2) inner	1057F/7506	21W (Bayonet)
• License (2)	2825	5W (T2 Wedge)
• Trunk (2)	6418	5W (Festoon)

## OBD2

The OBD2 system in the XK8 will return Diagnostic Trouble Code (DTC) P1111 when all systems are “in the green”. If you have reset the system and not driven it long enough for all tests to complete, you may get P1000. Get a good list of Generic and Jaguar specific DTCs, so when your car throws a DTC you don't recognize and your scan tool doesn't have a DTC library in memory, you can at least have a rough idea of what the system is telling you. The Workshop Manual has applicable DTC listings at the beginning of some chapters. Scan tools vary widely in sophistication and auto manufacturers are keen to keep some of their OBD2 details proprietary. I have an **Innova 3160e scanner** that can capture and graph live data. Smartphone apps like Torque Pro and Bluetooth Adapters allow for cordless monitoring of your car's systems.

Baseline scan your car's systems KeyON EngineOFF (KOEO) and read live data KeyON EngineRunning (KOER) while driving at varying speeds when things are running right, so you will be able to recognize normal range readings. Don't start replacing things on a single throw of a given DTC, but do use the OBD2 system to periodically monitor your car's systems and track trends over time. Develop a good diagnostic sense, proceeding in a logical manner to pinpoint the malfunctioning item. There are a number of YouTube videos to help you hone good troubleshooting skills.

All systems depend on each component doing its job correctly and consistently. Attempt to correlate or isolate the problem(s) to a single component or module. The simplest answer to the problem is usually the correct one, these days often a failed sensor/module or a bad electrical/wiring connection. Take care to not break other things on the way to fixing your initial problem. It's tempting to replace all other similar items when you have an assembly apart, but functioning parts are best left alone, unless the consequences of their failure are dire or there is visual evidence of their impending failure. Modern cars are designed and built for ease of assembly, not necessarily for ease of repair.

**Normal range OBD2 PIDs:**

Fuel 1 (Open Loop KOEO, Closed Loop KOER after warm up)

Fuel 2 (Open Loop KOEO, Closed Loop KOER after warm up)

Load (0% KOEO, 0 to 100% KOER)

ECT (-30 to 230°F)

STFT B1 (0 ± 10%) lost at key OFF

LTFT B1 (0 ± 10%) retained at key OFF

STFT B2 (0 ± 10%) lost at key OFF

LTFT B2 (0 ± 10%) retained at key OFF

FP (54 to 70 psi relative to MAP)

MAP at Idle (>20 inHg)

RPM (0 to 6400 rpm)

Speed (0 to 155 mph)

Advance (0 to 45° BTDC)

IAT (0 to 130°F)

MAF (0 to 40 lb/min)

TP (0 to 100%)

Lambda B1 S2 (cycles from .5 ± .5 V KOER)

Lambda B2 S2 (cycles from .5 ± .5 V KOER)

MIL (OFF)

Lambda B1 S1 Equivalency Ratio (1 ± .1 KOER)

Lambda Current B1 S1 (0 ± 5mA KOER) + = lean, - = rich

Lambda B2 S1 Equivalency Ratio (1 ± .1 KOER)

Lambda Current B2 S1 (0 ± 5mA KOER) + = lean, - = rich

## Used XK8 Buyer Advice

After reading and understanding information presented in this article, the following items should be included in your condition inspection. You should also line up a competent Jaguar mechanic to go over the target vehicle prior to money changing hands. Be aware that first owner costs are the highest because of depreciation. The second and third owner costs will be significantly less, provided you are able to care for the car yourself. Having a Jaguar is a bit like being married to a supermodel, in that you must be attentive to their needs to keep things happy.

1. Overall Condition and Mileage. ZZ Top recommends first looking at the purse, but I say first look at the driver's seat leather, cup holder/center armrest and pedal rubber. Does the car look as though it has been well cared for? The car should have no more than 120K mi to be a good candidate and it helps your pocketbook immensely if you can troubleshoot problems and do most of your own repairs. Look for coolant-free oil and oil-free coolant.
2. Service History and Seller Evaluation. Don't buy used Jaguars from dorks. Look for either parts receipts and labor invoices or seller mechanical knowledge and ability. Always speak to whoever maintained the car and do a reality check on any claims made (trust but verify).
3. Cooling Systems. Check coolant color (orange) and level. Pressurize the cooling system when cold for several hours at 15 psig to check for leaks under the car. Start the car and observe the exhaust during initial start and warm-up. Inspect fans, radiator fins and hoses for good condition and proper operation. Does the engine come up to temperature in five minutes in the middle of gauge range and stay there? The fans should cycle from OFF when cold, to Series (Slow) when warm and then to Parallel (Fast) when hot or A/C turned ON.
4. Engine Condition, Fluid Leaks and Noises. Look for all conditions indicating neglect or incomplete maintenance. If you can, remove plastic covers and disconnect each coil in turn for a few seconds to observe rpm drop. The engine should crank and start readily. Perform a compression check on all cylinders (~200 psig). Use an endoscope to inspect the cylinder walls and piston crowns. Check manifold pressure at idle. Listen for unusual tappet or primary chain noises. Check oil level and condition.
5. Engine Bay. Look for cleanliness and attention to detail. Are all fittings and parts OEM equivalents? Remove each firewall compartment cover and examine the systems contained. Ensure the covers are intact with two tabs and retainers. Check brake and power steering fluid levels and condition. Look for proper engine mount condition with a quick stab of throttle.
6. Drivetrain. Look for Guibo condition and leaking seals.
7. Suspension. Bounce on each wing to observe damper compression and rebound authority.
8. Steering and Brakes. Look for centering tendency, absence of slop and good braking authority. Look under car in the area of the brakes to ensure there are no caliper leaks. If you can get each wheel up in turn, check ball joints, bearings and observe smooth rotation.
9. Wheels and Tires. Visually evaluate tire type and tread, check for curb rash and condition.
10. Electrical and Lighting. Make sure all systems operate to spec both day and night. With engine running, check charging voltage at battery B+ (it should be about 14.5VDC at idle and greater than 12.35VDC engine OFF). With key ON, ensure that all Instrument Cluster indicator lamps are ON and that they all slowly go out after engine start. Check to see that the dimmer circuit works.
11. Entertainment Center and Instruments. Make sure all items operate to spec and radio antenna extends, retracts and stops. Operate all panel buttons and steering stalk functions both sides.

12. Soft Top. Cycle soft top and observe action. The pump should not sound labored and the top should close or open in <20 seconds. Check for proper window sequencing. Check external fabric, headliner condition and ensure soft top cover is available. Ensure any dash mat is well attached.

13. Interior and Seats. Inspect for leather condition, seat and steering column movement/position memory, lumbar inflation function and ensure headrests drop as seats are drawn forward and restore upon return. Ensure floor mats have plastic retention hooks. Verify that the glove box lid closes properly and locks.

14. Body, Paint and Corrosion. Operate all doors, boot, bonnet, fuel filler door and all locks both manual and remotely operated via the key fob. Look for nicks and overall finish condition. Inspect the welded body joint at door sills both sides.

15. Glazing. All Jaguar windshields will have some degree of pitting, but ensure glazing is otherwise in good condition. Check for window drop as each door is opened and rise as it is closed. Ensure windows roll all the way up, all the way down and rear window heater is functional.

16. Plastic and Rubber. Look at all plastic and rubber items in the engine bay, under the car and window and door seals.

17. Missing Items. Ensure alternator cooling scoop is in place under the car and the passenger side wiper arm pivot cap is not missing. Ensure there are two sets of black driver keys, a single green valet key, tool kit and compact spare tire are present and in good condition.

18. Smog Reports. Review for trends. Check miles per gallon on dash computer display and see if it makes sense. Ensure there are no alert lamps illuminated and no squawks on the panel message center. Check the exhaust tips for excessive carbon buildup.

19. OBD2 Scan. With your scanner attached, drive the car somewhere and shut it down for a few minutes. Start it up and drive it back. It may take multiple events before the OBD2 system logs a code. Capture 15 minutes of live scanner data at speed. Look particularly at coolant temperature, long term fuel trims, O<sub>2</sub> sensor readings and readings indicating catalyst condition.

20. Test Drive. Engine should idle smoothly and take throttle readily. Low end torque should be apparent and steering should be neutral and not twitchy. At low speed, the suspension should be stiff and at freeway speeds (and up) the car should be well under control regardless of road conditions. It should corner as though on rails with virtually no lean. Shift into manual (J gate) under a variety of conditions and observe results. There should be smooth shifting and the exhaust note should remain a low burble with no popping even under aggressive downshifting conditions. Engage and disengage cruise control and sport mode functions. Note all gauge readings and recheck miles per gallon on dash computer display.

**Jaguar XK8 Service**

	<b>Every</b>	
Change Oil (Pennzoil 10W-30 8 qts), Filter (Mahle OC602) and Drain Catch Can		5K mi
Add Berryman's B-12 to Full Fuel Tank	5K mi	
Inspect Wiper Blades (21") and Fill Washer Fluid	5K mi	
Inspect Battery Electrolyte	5K mi	
Inspect Tire Tread and Pressure (32 psig Cold)	5K mi	
Inspect Engine Cooling Fans (Off/Slow/Fast)	5K mi	
Inspect for Engine Leaks and Unusual Noises	5K mi	
Inspect Brake Pads, Rotors and Hand Brake	5K mi	
Inspect Rubber Boots for Damage	5K mi	
Inspect for Corrosion and/or Abnormal Wear	5K mi	
Inspect Mirrors and Central Locking System	5K mi	
Inspect Seats, Headrests and Safety Restraints	5K mi	
Inspect Horn, Headlamps, Fog Lamps and Hazard Flasher	5K mi	
Inspect Turn Signals, Brake Lamps and Interior Controls	5K mi	
Inspect Air Conditioning, Heating and Rear Defogger	5K mi	
Replace Brake Fluid (Pentosin DOT4 LV)	30K mi	
Replace Power Steering Fluid (Pentosin CHF 11S)	30K mi	
Replace or Clean Air Filter	30K mi	
Lubricate Hinge Points and Door Locks	30K mi	
Silicone Spray Rubber Items and Noxudol 750 Rust Prone Areas/Items		30K mi
Grease Rear Half-Shaft U-joints	30K mi	
Replace Fuel Filter (Mahle KL83)	60K mi	
Replace Transmission Filter Pan and Fluid (6-7 qts)	60K mi	
Replace Battery (H8-DLG)	60K mi	
Replace Coolant (Dex-Cool Orange 50/50 10 qts)	60K mi	
Replace Coolant Expansion Tank and Cap (MLD4400AB)	60K mi	
Replace Thermostat (AJ82697) and Outlet Pipe (AJ89486)	60K mi	
Check Heater Valve (MNA6711AC) and Pump (MJA6710AA) Operation		60K mi
Inspect Octopus Hose (MJA6728AC)	60K mi	
Replace Upper (2CN1174) and Lower (2CN1173) Coolant Hoses	90K mi	
Replace Coolant Pump (AJ88912/X)	90K mi	
Replace Serpentine Belt (6PK2310)	90K mi	
Replace Brake Pedal Position Switch (LJB6420BB)	90K mi	
Replace Spark Plugs (IFR5N-10)	90K mi	
Clean Fuel Injectors (AJ82363)	90K mi	
Replace Starter Relay (LJA6703AA)	90K mi	
Clean Mass Air Flow Sensor (C2S2670)	90K mi	
Replace Front Wheel Speed Sensor Cables	90K mi	
Replace Engine Side Oil Cooler Hoses	90K mi	
Replace Front Anti-Roll Bar Bushings	120K mi	
Replace Upper Front Shock Mounts (MJA2170BD)	120K mi	
Replace Front Shocks (BE5-6726H0)	120K mi	
Replace Upstream Air/Fuel Sensors (C2C7359)	120K mi	
Replace Valley Hoses (AJ86326 and NNE3946CA)	120K mi	
Replace Power Steering Hoses and Rod Boots	120K mi	
Replace Soft Top Hydraulic Hoses	120K mi	
Replace Differential Fluid (Redline 75W90 2 qts)	120K mi	
Replace Cam Position Sensors (LRA1646BC and AJ84290)	120K mi	
Replace Crankcase Breather Pipes (AJ88622 and AJ87221)	120K mi	
Replace Rear (BE5-6727H0) Shocks	150K mi	
Replace Front, Rear and Steering Ball Joints and Bushings	150K mi	
Replace Driveshaft Flex-Disc (CBC8996)	150K mi	
Replace Radiator	150K mi	